

# DATA SHEET

## Specifications & Performance

### Certified Quality



Quality System  
ISO 9001 Certified



Environmental Management System  
ISO 14001 Certified



Warren Rupp, Inc.  
A Unit of IDEX Corporation  
800 N. Main St.,  
Mansfield, Ohio 44902 USA  
Telephone 419.524.8388  
Fax 419.522.7867  
SANDPIPERPUMP.COM



© Copyright 2016 Warren Rupp, Inc.  
All rights reserved

# Model S20

## Metallic Design Level 1

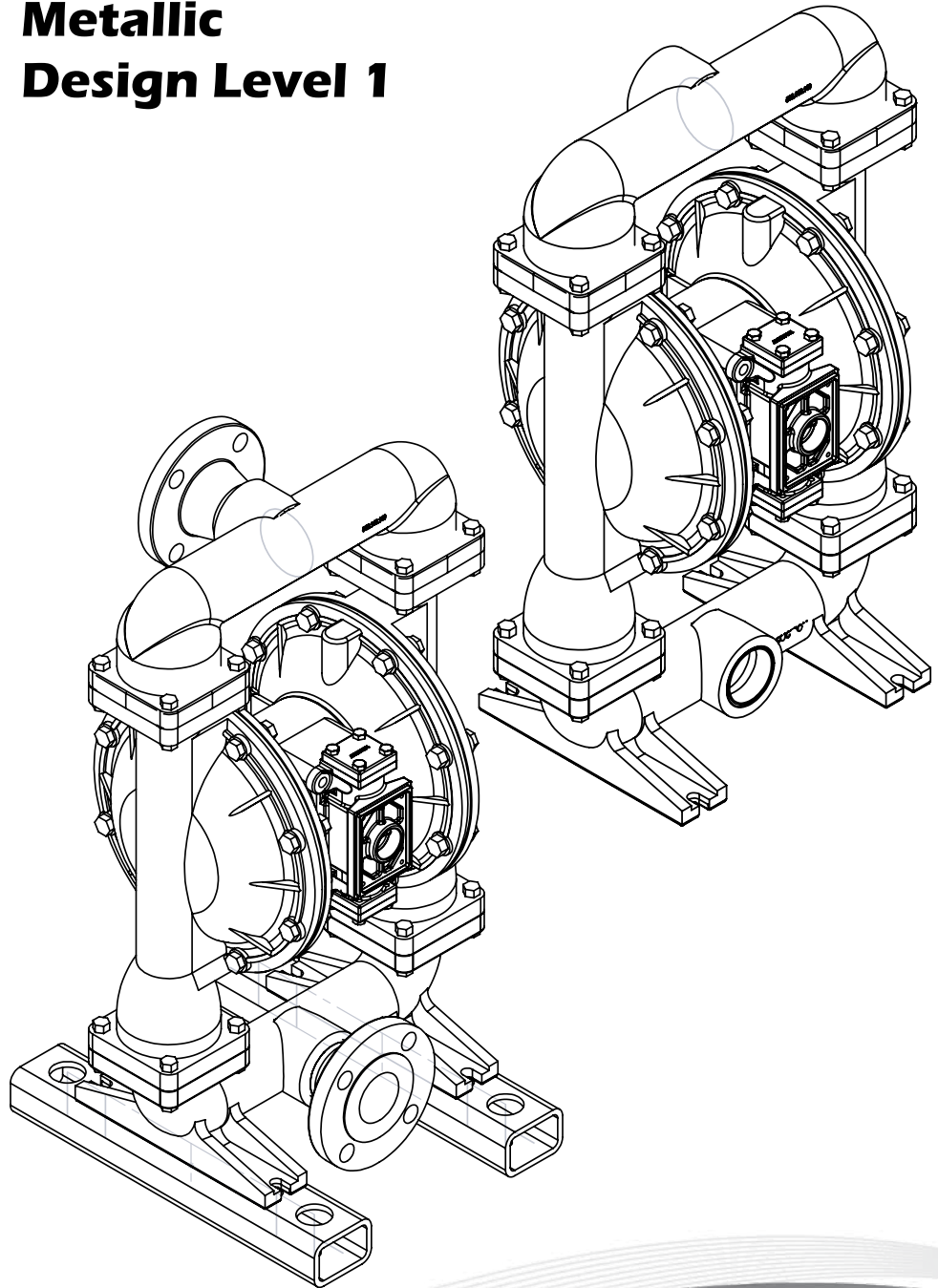

**SANDPIPER**<sup>®</sup>  
A WARREN RUPP, INC. BRAND

SANDPIPERPUMP.COM

# Explanation of Pump Nomenclature

Your Model #: **S**  
 (fill in from pump nameplate)

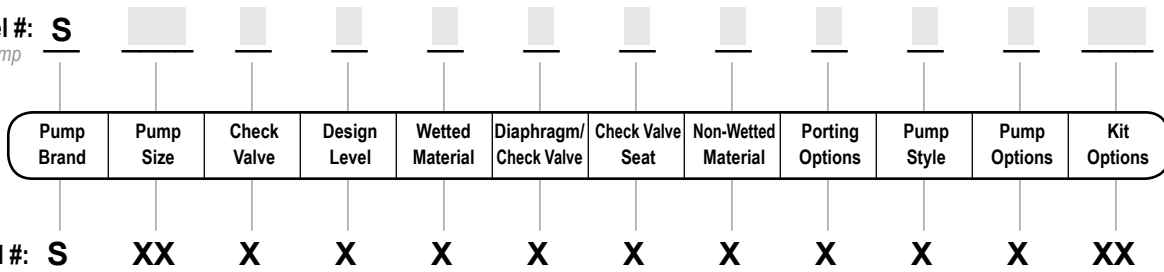

**Pump Brand**  
 S SANDPIPER®

**Pump Size**  
 20 2"

**Check Valve Type**  
 B Ball  
 W Weighted

**Design Level**  
 1 Design Level

**Wetted Material**  
 A Aluminum  
 I Cast Iron  
 S Stainless Steel  
 H Alloy C  
 X Unpainted Aluminum

**Diaphragm/Check Valve Materials**  
 1 Santoprene/Santoprene  
 2 PTFE-Santoprene/PTFE  
 B Nitrile/Nitrile  
 C FKM/PTFE  
 E EPDM/EPDM  
 I EPDM/Santoprene  
 G PTFE-Neoprene/PTFE  
 M Santoprene/PTFE  
 N Neoprene/Neoprene  
 Z One-Piece Bonded/PTFE

**Check Valve Seat**  
 A Aluminum  
 B Nitrile  
 C Carbon Steel  
 E EPDM  
 N Neoprene  
 S Stainless Steel  
 T PTFE  
 V FKM  
 W UHMW Polyethylene

**Non-Wetted Material Options**  
 A Painted Aluminum  
 I Cast Iron  
 J Painted Aluminum w/PTFE Coated Hardware  
 S Stainless Steel with Stainless Steel Hardware  
 Y Painted Aluminum with Stainless Steel Hardware  
 Z Cast Iron with Stainless Steel Hardware

**Porting Options**  
 N NPT Threads  
 B BSP (Tapered) Threads  
 R Raised Face 150# Threaded ANSI Flange  
 W Welded Raised Face #150 ANSI Flanged Manifolds

**Pump Style**  
 S Standard

**Pump Options**  
 0 None  
 6 Metal Muffler

**Kit Options**  
 00. None  
 P0. 10.30VDC Pulse Output Kit  
 P1. Intrinsically-Safe 5.30VDC, 110/120VAC 220/240 VAC Pulse Output Kit  
 P2. 110/120 or 220/240VAC Pulse Output Kit  
 E0. Solenoid Kit with 24VDC Coil  
 E1. Solenoid Kit with 24VDC Explosion-Proof Coil  
 E2. Solenoid Kit with 24VAC/12VDC Coil  
 E3. Solenoid Kit with 12VDC Explosion-Proof Coil  
 E4. Solenoid Kit with 110VAC Coil

**Kit Options (continued)**  
 E5. Solenoid Kit with 110VAC Explosion-Proof Coil  
 E6. Solenoid Kit with 220VAC Coil  
 E7. Solenoid Kit with 220VAC Explosion-Proof Coil  
 E8. Solenoid Kit with 110VAC, 50 Hz Explosion-Proof Coil  
 E9. Solenoid Kit with 230VAC, 50 Hz Explosion-Proof Coil  
 SP. Stroke Indicator Pins

A1. Solenoid Kit with 12 VDC ATEX Compliant Coil  
 A2. Solenoid Kit with 24 VDC ATEX Compliant Coil  
 A3. Solenoid Kit with 110/120 VAC 50/60 Hz ATEX Compliant Coil  
 A4. Solenoid Kit with 220/240 VAC 50/60 Hz ATEX Compliant Coil

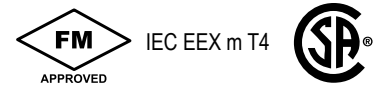

IEC EEx m T4  
 APPROVED  
**Note:** Pump models equipped with these explosion-proof solenoid kit options E1, E3, E5, E7, E8 or E9, are certified and approved by the above agencies. They are NOT ATEX compliant.

Your Serial #: (fill in from pump nameplate) \_\_\_\_\_

## ATEX Detail

	ATEX Detail	Wetted Material Options	Non-Wetted Material Options	Pump Options	Kit Options
	II 1G c T5 II 1D c T100°C I M1 c I M2 c	H, I, S	I, S, Z	6	00
	II 2G c T5 II 2D c T100°C	A, H, I, S, X	A, I, S, Y, Z	6	00
	II 2G Ex ia c IIC T5 II 2D Ex c iaD 20 IP67 T100°C	A, H, I, S, X	A, I, S, Y, Z	6	P1
	II 2G EEx m c II T5 II 2D c IP65 T100°C	A, H, I, S, X	A, I, S, Y, Z	6	A1, A2, A3, A4

# Performance

## S20 METALLIC

### SUCTION/DISCHARGE PORT SIZE

- 2" NPT (internal)
- 2" BSP Tapered (internal)
- 2" ANSI 150# Raised Face Flanged

### CAPACITY

- 0 to 150 gallons per minute (0 to 567 liters per minute)

### AIR DISTRIBUTION VALVE

- No-lube, no-stall design

### SOLIDS-HANDLING

- Up to .25 in. (6mm)

### HEADS UP TO

- 125 psi or 289 ft. of water (8.6 Kg/cm<sup>2</sup> or 86 meters)

### DISPLACEMENT/STROKE

- .42 Gallon / .1.59 liter

### MAXIMUM OPERATING PRESSURE

- 125 psi (8.6 bar)

### SHIPPING WEIGHT

- Aluminum 69 lbs. (31kg)
- Cast Iron 129 lbs. (59kg)
- Stainless Steel 114 lbs. (52kg)

## MODEL S20 Metallic Performance Curve

Performance based on the following: elastomer fitted pump, flooded suction, water at ambient conditions. The use of other materials and varying hydraulic conditions may result in deviations in excess of 5%.

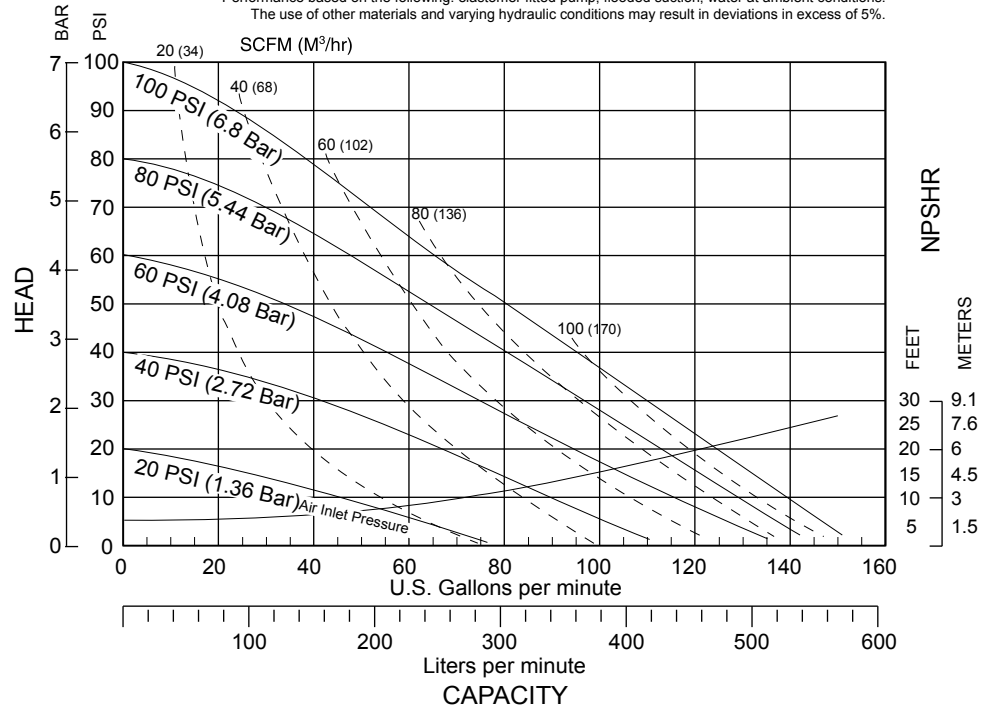

# Materials

Material Profile:	Operating Temperatures:	
	Max.	Min.
<b>Conductive Acetal:</b> Tough, impact resistant, ductile. Good abrasion resistance and low friction surface. Generally inert, with good chemical resistance except for strong acids and oxidizing agents.	190°F 88°C	-20°F -29°C
<b>EPDM:</b> Shows very good water and chemical resistance. Has poor resistance to oils and solvents, but is fair in ketones and alcohols.	280°F 138°C	-40°F -40°C
<b>FKM:</b> (Fluorocarbon) Shows good resistance to a wide range of oils and solvents; especially all aliphatic, aromatic and halogenated hydrocarbons, acids, animal and vegetable oils. Hot water or hot aqueous solutions (over 70°F(21°C)) will attack FKM.	350°F 177°C	-40°F -40°C
<b>Hytrel®:</b> Good on acids, bases, amines and glycols at room temperatures only.	220°F 104°C	-20°F -29°C
<b>Neoprene:</b> All purpose. Resistance to vegetable oils. Generally not affected by moderate chemicals, fats, greases and many oils and solvents. Generally attacked by strong oxidizing acids, ketones, esters and nitro hydrocarbons and chlorinated aromatic hydrocarbons.	200°F 93°C	-10°F -23°C
<b>Nitrile:</b> General purpose, oil-resistant. Shows good solvent, oil, water and hydraulic fluid resistance. Should not be used with highly polar solvents like acetone and MEK, ozone, chlorinated hydrocarbons and nitro hydrocarbons.	190°F 88°C	-10°F -23°C
<b>Nylon:</b> 6/6 High strength and toughness over a wide temperature range. Moderate to good resistance to fuels, oils and chemicals.	180°F 82°C	32°F 0°C

<b>Polypropylene:</b> A thermoplastic polymer. Moderate tensile and flex strength. Resists strong acids and alkali. Attacked by chlorine, fuming nitric acid and other strong oxidizing agents.	180°F 82°C	32°F 0°C
<b>PVDF:</b> (Polyvinylidene Fluoride) A durable fluoroplastic with excellent chemical resistance. Excellent for UV applications. High tensile strength and impact resistance.	250°F 121°C	0°F -18°C
<b>Santoprene®:</b> Injection molded thermoplastic elastomer with no fabric layer. Long mechanical flex life. Excellent abrasion resistance.	275°F 135°C	-40°F -40°C
<b>UHMW PE:</b> A thermoplastic that is highly resistant to a broad range of chemicals. Exhibits outstanding abrasion and impact resistance, along with environmental stress-cracking resistance.	180°F 82°C	-35°F -37°C
<b>Urethane:</b> Shows good resistance to abrasives. Has poor resistance to most solvents and oils.	150°F 66°C	32°F 0°C
<b>Virgin PTFE:</b> (PFA/TFE) Chemically inert, virtually impervious. Very few chemicals are known to chemically react with PTFE; molten alkali metals, turbulent liquid or gaseous fluorine and a few fluoro-chemicals such as chlorine trifluoride or oxygen difluoride which readily liberate free fluorine at elevated temperatures.	220°F 104°C	-35°F -37°C

Maximum and Minimum Temperatures are the limits for which these materials can be operated. Temperatures coupled with pressure affect the longevity of diaphragm pump components. Maximum life should not be expected at the extreme limits of the temperature ranges.

### Metals:

<b>Alloy C:</b> Equal to ASTM494 CW-12M-1 specification for nickel and nickel alloy.
<b>Stainless Steel:</b> Equal to or exceeding ASTM specification A743 CF-8M for corrosion resistant iron chromium, iron chromium nickel and nickel based alloy castings for general applications. Commonly referred to as 316 Stainless Steel in the pump industry.

For specific applications, always consult the Chemical Resistance Chart.

- Ambient temperature range:** -20°C to +40°C  
**Process temperature range:** -20°C to +80°C for models rated as category 1 equipment  
 -20°C to +100°C for models rated as category 2 equipment

In addition, the ambient temperature range and the process temperature range do not exceed the operating temperature range of the applied non-metallic parts as listed in the manuals of the pumps.

# Dimensional Drawings

## S20 Metallic

Dimensions in inches (mm dimensions in brackets). Dimensional Tolerance:  $\pm 1/8"$  ( $\pm 3\text{mm}$ )

The dimensions on this drawing are for reference only. A certified drawing can be requested if physical dimensions are needed.

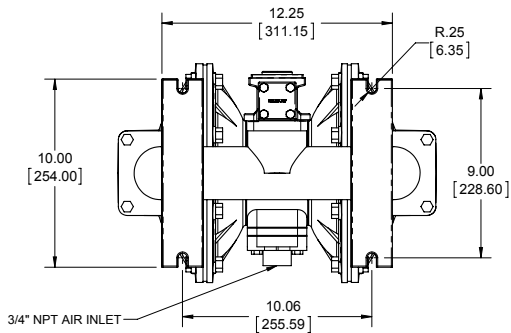
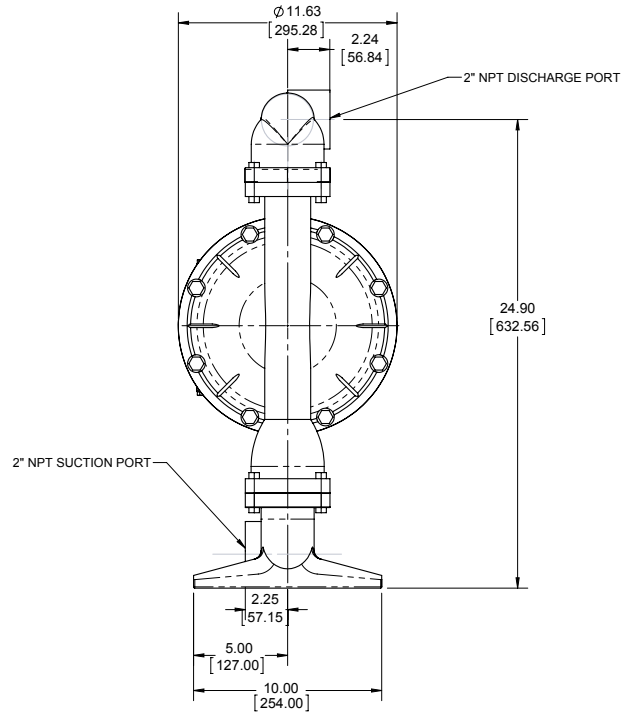
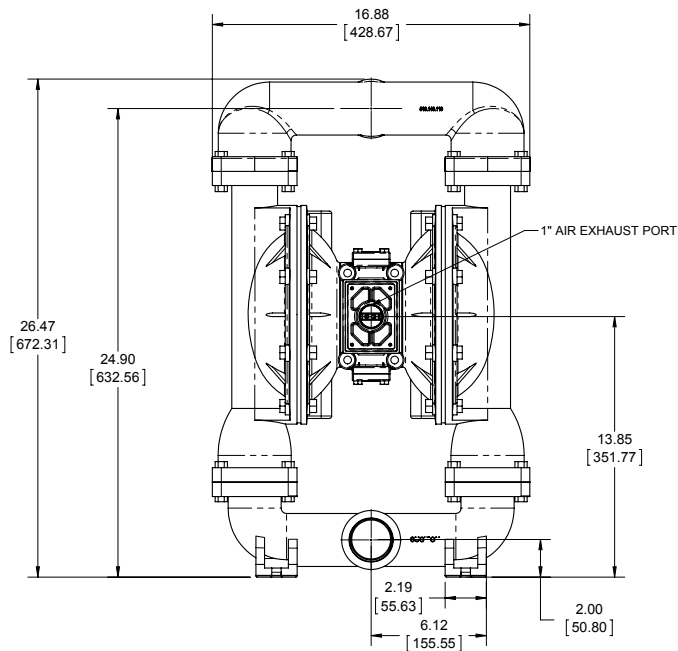

BOTTOM VIEW

# Dimensional Drawings

## S20 Metallic

Dimensions in inches (mm dimensions in brackets). Dimensional Tolerance:  $\pm 1/8"$  ( $\pm 3\text{mm}$ )

The dimensions on this drawing are for reference only. A certified drawing can be requested if physical dimensions are needed.

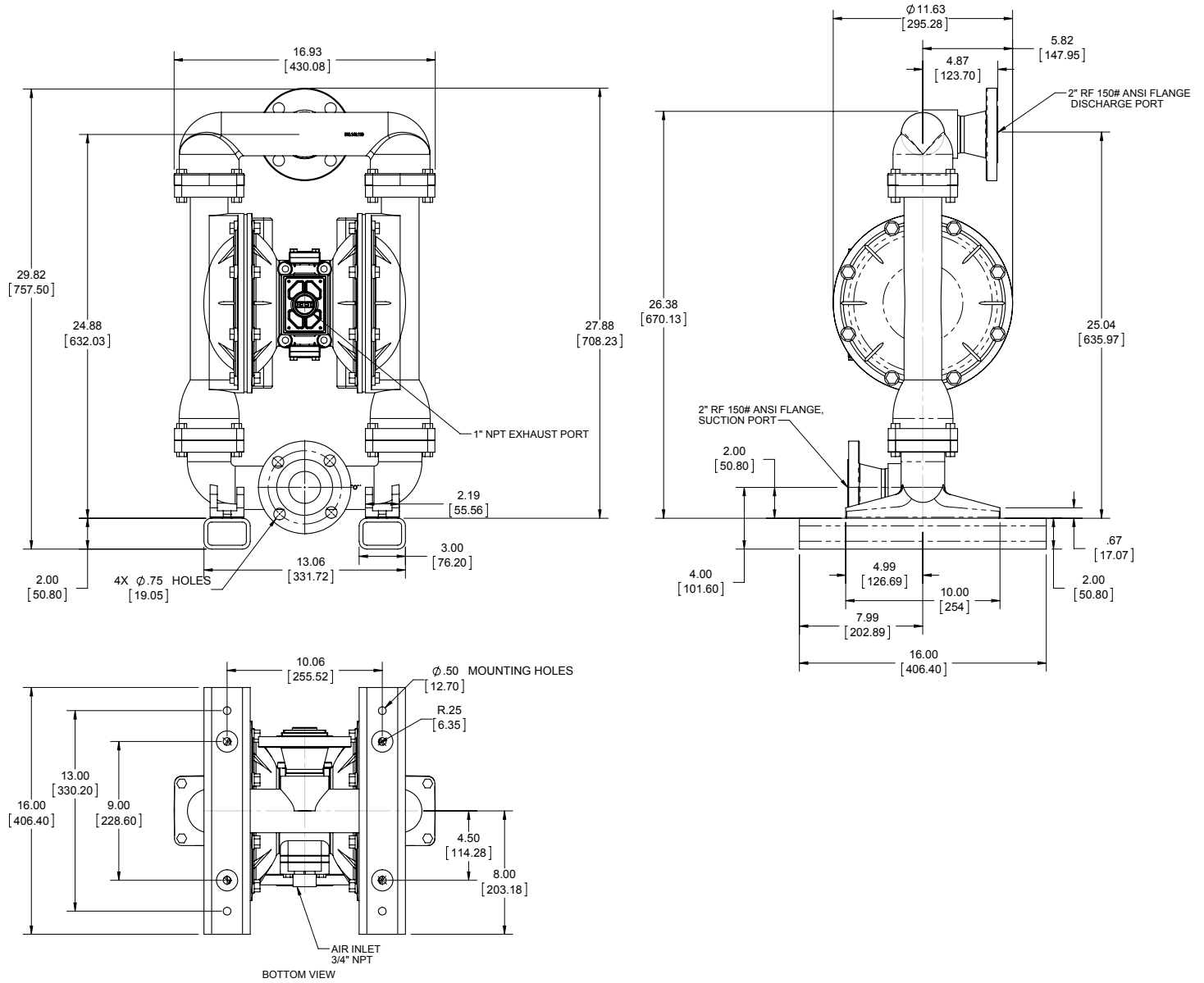

# 5 - YEAR Limited Product Warranty

Warren Rupp, Inc. ("Warren Rupp") warrants to the original end-use purchaser that no product sold by Warren Rupp that bears a Warren Rupp brand shall fail under normal use and service due to a defect in material or workmanship within five years from the date of shipment from Warren Rupp's factory. Warren Rupp brands include Warren Rupp®, SANDPIPER®, MARATHON®, PortaPump®, SludgeMaster™ and Tranquilizer®.

~ See [sandpiperpump.com/content/warranty-certifications](http://sandpiperpump.com/content/warranty-certifications) for complete warranty, including terms and conditions, limitations and exclusions. ~

**WARREN  
RUPP, INC.**

## Declaration of Conformity

**Manufacturer: Warren Rupp, Inc., 800 N. Main Street  
Mansfield, Ohio, 44902 USA**

Certifies that Air-Operated Double Diaphragm Pump Series: HDB, HDF, M Non-Metallic, S Non-Metallic, M Metallic, S Metallic, T Series, G Series, U Series, EH and SH High Pressure, RS Series, W Series, SMA and SPA Submersibles, and Tranquilizer® Surge Suppressors comply with the European Community Directive 2006/42/EC on Machinery, according to Annex VIII. This product has used Harmonized Standard EN809:1998+A1:2009, Pumps and Pump Units for Liquids - Common Safety Requirements, to verify conformance.

David Roseberry  
Signature of authorized person

David Roseberry  
Printed name of authorized person

Revision Level: F

October 20, 2005  
Date of issue

Engineering Manager  
Title

August 23, 2012  
Date of revision

**IBEX**

**CE**

# **WARREN RUPP, INC.**

## **EC / EU Declaration of Conformity**

The objective of the declaration described is in conformity with the relevant Union harmonisation legislation: Directive 94/9/EC (until April 19, 2016) and Directive 2014/34/EU (from April 20, 2016).

**Manufacturer:**

Warren Rupp, Inc.  
A Unit of IDEX Corporation  
800 North Main Street  
P.O. Box 1568  
Mansfield, OH 44902 USA

**Applicable Standard:**

EN13463-1: 2001  
EN13463-5: 2003  
EN60079-25: 2004

**Harmonised Standard:**

EN13463-1: 2009  
EN13463-5: 2011  
EN60079-25:2010

The harmonised standards have been compared to the applicable standards used for certification purposes and no changes in the state of the art technical knowledge apply to the listed equipment.

**AODD Pumps and Surge Suppressors**

Technical File No.: 203104000-1410/MER

**AODD (Air-Operated Double Diaphragm) Pumps**

EC Type Examination Certificate No. Pumps: KEMA 09ATEX0071 X

DEKRA Certification B.V. (0344)  
Meander 1051  
6825 MJ Arnhem  
The Netherlands

**Hazardous Locations Applied:**

I M1 c	II 1 G c T5
II 2 G Ex ia c II CT5	II 1 D c T100°C
II 2 D Ex c iaD 20 IP67 T100°C	II 2 G c T5
II 2 G Eex m c II T5	II 2 D c T100°C
II 2 D c IP65 T100°C	

**SANDPIPER®**  
A WARREN RUPP, INC. BRAND

**Tranquilizer®**

DATE/APPROVAL/TITLE:  
18 March 2016

*David Roseberry*  
David Roseberry, Director of Engineering

**IDEX**