

MEMDOS E/DX

Motor-driven Diaphragm Dosing Pump



EN

02

Operation manual

Read this operation manual before start-up!
To be retained for future reference.

List of Contents

1. General and Safety Instructions	3
2. General	7
2.1 Proper use	7
2.2 Structure of the dosing pump	7
3. Function	8
4. Dimensional drawings	9
5. Technical data	11
5.1 Electric motor data	13
5.2 Technical data ATE servomotor MEMDOS E (optional)	14
6. Performance curves	15
7. Installation	17
7.1 General information	17
7.2 Installation location	18
7.3 Drain pipe	18
7.4 Electrical connection of the pump	18
7.5 Wiring diagrams for ATE servomotor for stroke length adjustment	21
7.6 Level control	22
7.7 Back-pressure and safety valves	22
7.8 Injection nozzle installation	22
7.9 Installation example	23
8. Operation	24
8.1 Stroke length adjustment	24
8.2 MEMDOS DX operating elements.....	24
8.3 Switching on/off	24
8.4 Operating mode selection	24
8.5 Alarm.....	25
8.6 Other settings.....	26
8.7 Factory setting	26
8.8 Connections and cable assignments	26
9. Start-up	28
9.1 Start-up of MEMDOS E with ATE servomotor	28
10. Shutdown	29
10.1 Disposal of old equipment	29
Device revision	29
11. Maintenance	30
11.1 Lubrication.....	30
11.2 Maintenance of the bearings	30
11.3 Maintenance of the ATE servomotor (optional)	30
11.4 Diaphragm replacement.....	30
11.5 Valves	32
12. Explosion-proof dosing pumps (ATEX)	36
12.1 General	36
12.2 Special conditions.....	36
12.3 Dosing of flammable media	36
13. Troubleshooting	37
14. Spare parts	38
15. External vent (optional)	43
Index	44
Warranty claim	46
CE declaration of conformity	47

1. General and Safety Instructions

1.1 General

This operation manual contains basic instructions to be followed during installation, operation and maintenance. It is therefore essential for the assembler and the responsible personnel/operator to read this operation manual before installation and start-up, and it must remain available at the place of installation at all times.

Besides the general safety instructions in this "Safety" section, the special safety instructions inserted in the other sections are also to be followed.

1.2 Identification of safety instructions in this operation manual

Disregarding the safety instructions in this operation manual may cause danger to persons, the environment and the system. Safety instructions are identified by the following symbols:

DANGER!

Indicates an immediate danger.

Failure to follow this instruction will lead to death or extremely serious injuries.



WARNING!

Indicates a potentially hazardous situation. Failure to follow this instruction can lead to death or extremely serious injuries.

CAUTION!

Indicates a potentially hazardous situation. Failure to follow this instruction can lead to minor injuries or damage to property.

ATTENTION! or NOTICE!

Failure to follow these safety instructions may endanger the machine and its functions.

IMPORTANT!

This indicates additional information that makes work easier and ensures trouble-free operation.



Information attached directly to the dosing pump, such as

- cable markings
- markings for fluid connections

must be followed without fail and must remain fully legible at all times.

1.3 Personnel qualifications and training

The personnel employed for operation, maintenance, inspection, and installation must be suitably qualified for this work. The responsibilities, areas of competence and personnel supervision must be clearly defined by the operating company. Personnel who do not have the required know-how must be duly trained and instructed. If necessary, this can also be done by the manufacturer/supplier on behalf of the operating company. In addition, the operating company must ensure that the personnel are fully familiar with, and have understood the contents of this operation manual.

1.4 Important safety instructions

When installing and using this electrical device, basic safety precautions should always be followed, including the following:

ATTENTION!

Read and follow all instructions! Keep this operation manual for future reference!



WARNING!

To reduce the risk of injury, do not permit children to use this product unless they are closely supervised at all times.

**WARNING!**

Risk of electric shock. Connect the device only to a SCHUKO socket outlet protected by a ground fault circuit interrupter (GFCI). Contact a qualified electrician if you are uncertain whether the socket is protected by a GFCI.

Do not bury the cable. Fix the cable to minimise possible damage due to lawn mowers, hedge trimmers, and other equipment.

WARNING!

To reduce the risk of electric shock, replace the cable immediately if damaged.

WARNING!

To reduce the risk of electric shock, do not use an extension cable to connect the device to the power supply; use an appropriately located outlet socket.

1.5 Hazards due to failure to follow safety instructions

Failure to follow the safety instructions may endanger not only persons, but also the environment and the device. Failure to follow the safety instructions may invalidate any damage claims.

The following hazards in particular may result:

- failure of major equipment functions
- failure of required maintenance and repair methods
- danger to persons due to electrical, mechanical and chemical effects
- danger to the environment due to leakage of hazardous substances

1.6 Safety-conscious working

The safety instructions contained in this operation manual must be observed. The operating company is responsible for ensuring compliance with local safety regulations. Faults that may affect safety must be repaired immediately!

1.7 Safety instructions for the operating company/operator

Leakages of dangerous substances (e.g. aggressive, toxic), for example due to a broken diaphragm, must be suitably drained away so that they do not cause danger to persons or the environment. Statutory regulations must be observed.

Dangers due to electric current must be prevented (for further details, refer to the VDE¹⁾ regulations and regulations of the local power supply companies).

¹⁾ German Association for Electrical, Electronic & Information Technologies

Separate regulations must be observed if the MEMDOS E is operated in areas with a potentially explosive atmosphere. The operating company must determine the explosion hazard (area classification) and select the appropriate equipment. Further information can be found in paragraph 7.1 (Installation), paragraph 7.4 (Electrical connection) and section 13 (Explosion-proof dosing pumps).

1.8 Safety instructions for inspection, maintenance and installation work

The operating company must ensure that all maintenance, inspection and installation work is undertaken by authorised and duly qualified personnel, who have studied this operation manual.

Any work on the machine must only be carried out after it has been brought to a complete stop. Always follow the procedure specified in the operation manual for shutting down the dosing pump/system.

Dosing pumps or systems which convey hazardous media must be decontaminated.

All safety and protective equipment must be re-attached and activated immediately after the work has been completed.

CAUTION!

Particular care must be taken when repairing the MEMDOS E if used in areas with a potentially explosive atmosphere. Due to the risk of sparking, care must be taken to prevent metal parts or tools knocking against one another. When repairing, it is better to move the dosing pump out of the area with a potentially explosive atmosphere.



The instructions given in paragraph 7.2 "Installation location" and section 9 "Start-up" must be observed before start-up.

1.9 Unauthorised modification and production of spare parts

The device may only be modified or converted in consultation with the manufacturer. Use only the manufacturer's spare parts and accessories. Otherwise the warranty is invalidated.

1.10 Inadmissible operating practices

Any methods of operation other than those described in section 2 "Proper use" are not permitted, and will cancel any manufacturer liability under the warranty.

1.11 Dosing of chemicals

CAUTION!

When working on dosing systems, the local accident prevention regulations must be observed and the specified personal protective equipment must be worn. The following standard protective clothing is recommended, depending on the hazardousness of the metered medium:



Protective clothing



Protective gloves



Protective goggles

All persons responsible for assembly and maintenance of piping, hoses and accessories should wear this protective equipment.

Before working on the dosing pump and system, disconnect it from the mains supply and prevent it from being switched on.

CAUTION!

Any chemical still present in the dosing head may spray out when the power supply is reconnected. This may lead to chemical or other burns to the face and hands. Dosing lines must always be connected before switching on again.



The chemical resistance of the construction materials in the pump must be verified before dosing aggressive media!

The pump dosing head and the system connections and lines may be under pressure. Working on the dosing system requires special safety precautions and is allowed only for suitably trained personnel:

CAUTION!

Chemical may spray out. This may lead to chemical or other burns. Always release the pressure before starting work on the dosing pump.



Before working on the dosing head, valves and connections, flush the dosing pump with a harmless medium (water in most cases), to avoid unintentional contact with the metered medium.

WARNING!

Never look into the open end of a clogged line or valve. Chemical may flow out unexpectedly and cause chemical or other burns to face and hands.



Before start-up, all screw connections must be inspected for correct tightness and leak-tightness, and must be re-tightened using an appropriate tool if necessary.

**CAUTION!**

If connections at the dosing head are loosened during operation, for venting or other reasons, leaking chemical must be removed properly. This is the only way to avoid health hazards due to chemicals, and chemical corrosion of the dosing pump. Leaking chemical may also damage the diaphragm at its mounting edge.

ATTENTION!

If changing the chemical, check the materials in the pump and other system parts for chemical resistance. If there is a danger of chemical reaction between the different media, clean thoroughly beforehand.

IMPORTANT!

To operate the pump, mount the fan cowl in order to ensure sufficient cooling of the motor.

The protection class of the control unit is only ensured if the connection ports are protected by caps or the standard connectors are inserted.

**DANGER!**

Fire hazard. Shock wave: parts may fly off and cause fatal injury. MEMDOS DX must never be used in areas with a potentially explosive atmosphere.

**CAUTION!**

Under certain operating conditions, the drive motor of the DX version might heat up considerably. This may cause burns to the hands. To avoid unintentional contact, provide an appropriate safety device.

**WARNING!****Lethal voltage!**

Adjustment work inside the ATE servomotor (optional for MEMDOS E) must be carried out carefully. Connections and internal limit switches might be live. Additional limit switches might be live even when the auxiliary voltage is switched off (ATE servomotor). After installation work on the ATE servomotor, or before start-up, re-attach the cover.

**1.12 Transportation**

No special devices are required for transportation of the dosing pumps. However, it is advisable to choose a transport method appropriate for the weight of the dosing pumps (e.g. transport trolley). If transporting with the oil drained, the dosing pump should preferably be placed in the horizontal position. Otherwise, stability must be ensured by screwing it onto the transport frame.

1.13 Scope of delivery**IMPORTANT!**

Carefully unpack the dosing pump and any accompanying accessories ordered, so that small parts are not left inside the packaging. Compare the delivery content with the delivery note immediately. If there are any discrepancies, find out the cause.



The following are part of the scope of delivery:

- MEMDOS dosing pump
- Suction and discharge side connections
- Gear oil
- 2x cables (for MEMDOS DX)
- Operation manual
- ATE servomotor (optional)
- Separate fan (optional)

2. General

2.1 Proper use

The device is intended for the following purpose only: the conveying and dosing of chemicals.

Operating safety is guaranteed only if the device is used for its intended purpose. Use for any other purpose is not permitted and will cancel any liability under the warranty. The operating conditions described in section 5 "Technical Data" must be observed!

2.2 Structure of the dosing pump

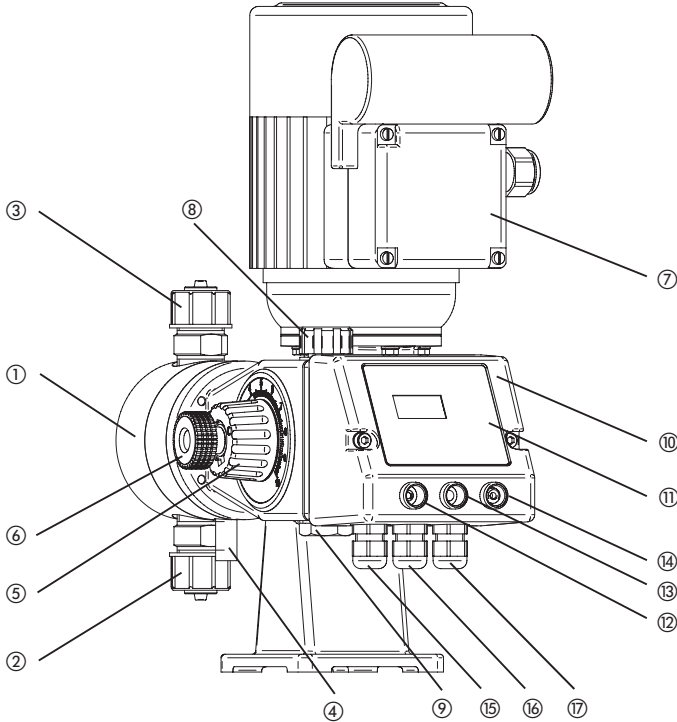

- ① Dosing head
- ② Suction side valve
- ③ Discharge side valve
- ④ Drain pipe
- ⑤ Stroke length adjustment
- ⑥ Stroke length adjustment lock
- ⑦ Motor terminal box (MEMDOS E power supply)
- ⑧ Oil inlet
- ⑨ Oil outlet
- ⑩ Control unit (MEMDOS DX)
- ⑪ Operating panel with display
- ⑫ "External switch-off" contact
- ⑬ "Level input" contact
- ⑭ "External control" contact
- ⑮ Power supply (MEMDOS DX)
- ⑯ Motor connection
- ⑰ Warning alarm relay

3. Function

Motor-driven diaphragm dosing pumps of the MEMDOS series are used in industry in the process engineering sector, and in water treatment and wastewater processing.

The MEMDOS E and MEMDOS DX are available in two overall sizes:

- Size 1: max 160 l/h delivery capacity
- Size 2: max 380 l/h delivery capacity

MEMDOS E

The MEMDOS E is used where no control is required for constant dosing. In this case, the power supply is connected directly to the motor terminal box. To adapt the dosing capacity, either the stroke length can be adjusted manually from 0 to 100%, or the motor speed can be controlled by means of a separate frequency converter. The MEMDOS E is optionally available with electric remote adjustment of the stroke length (ATE).

The MEMDOS E can be operated in Zone 1 hazardous areas if the corresponding drive is taken into consideration. Further information can be found in section 12.

MEMDOS DX

The "smart" MEMDOS DX is used where the dosing pump is to be integrated in controls or control circuits. The MEMDOS DX allows adaptation to a large variety of different control signals and system monitoring equipment. The signals required for external activation of the dosing pump can be from simple potential-free closing contacts of water meters or controllers, or analogue 0/4...20 mA signals. For contact actuation (pulse control), the stroke frequency can be adapted by division or multiplication. For internal operation (own stroke), the dosing pump can be adjusted continuously between 0 and max. 142 strokes/min, depending on version.

Principle of operation

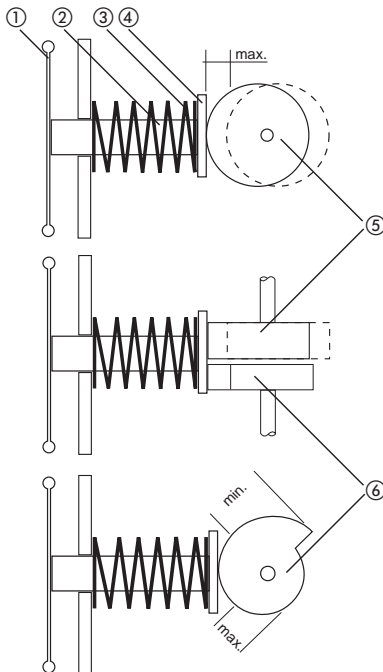

- ① Diaphragm
- ② Diaphragm rod
- ③ Return spring for suction stroke
- ④ Tappet plate
- ⑤ Drive eccentric
- ⑥ Stroke limit eccentric

Like the roller bearings, the worm gear set of the single-speed gear runs in an oil bath. Dosing takes place when movement of the drive eccentric ⑤ causes movement of the diaphragm rod ②. The suction stroke is produced by the return movement due to spring force. Stroke length is adjusted by limiting the tappet return movement using a manually adjustable eccentric disc as the end stop (stroke limiting eccentric ⑥). The adjustment range is from 0 to 100%.

4. Dimensional drawings

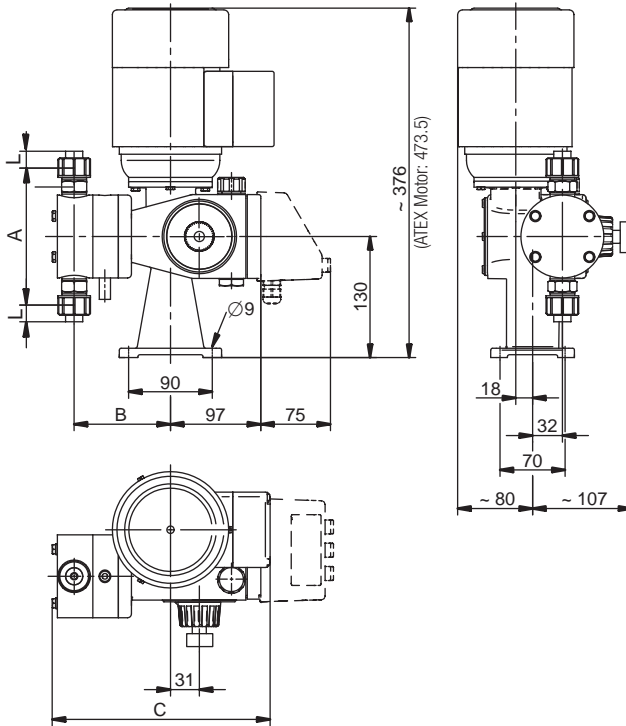

Dimensional drawing MEMDOS E/DX 4..0.156

E/DX	A	B	C	Connection	L
4...26	118	95	222	6/12	13
50	153	104	234	6/12	13
75, 76	153	104	234	ø 16 internal	17
110...156	246	117	259	ø 16 internal	22

All dimensions in mm

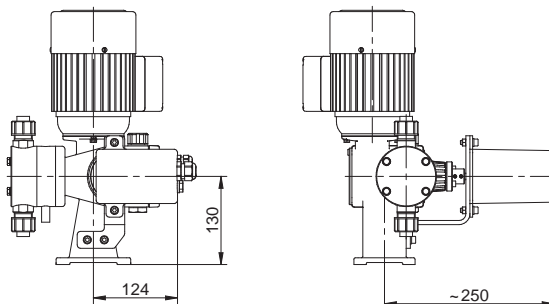

Dimensional drawing MEMDOS E 4..0.156 ATE

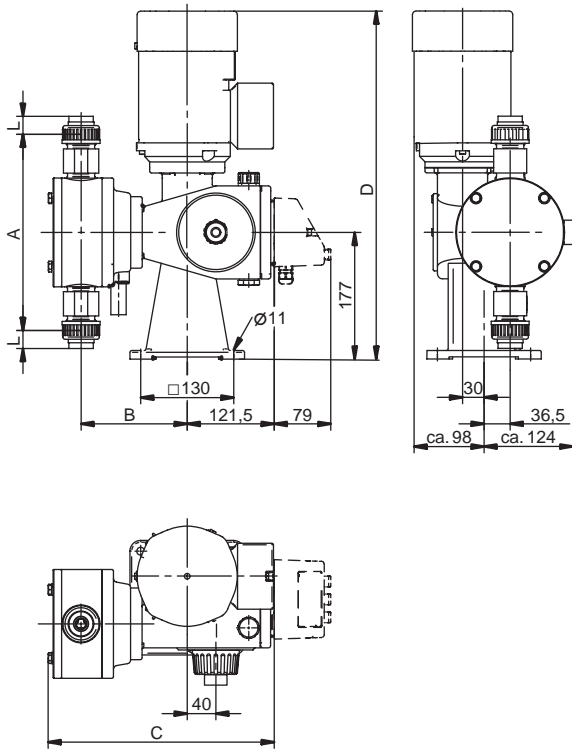

Dimensional drawing MEMDOS E/DX 160...380

Type	A	B	C	D	L*	D with ATEX motor
E 160..0.260	278	148	317	469 approx.	22	632
DX 160..0.260	278	148	317	486 approx.	22	
E 300...380	318	153.5	320	469 approx.	22	632
DX 300...380	318	153.5	320	486 approx.	22	

* Dimension L for glue-in connection, internal \varnothing 20, all dimensions in mm

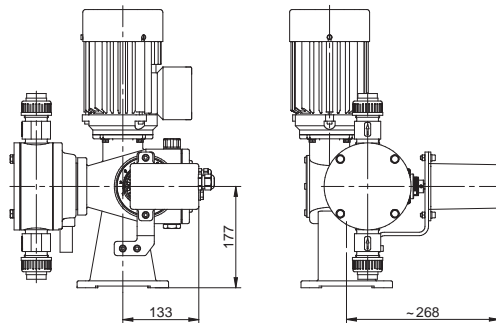

Dimensional drawing MEMDOS E 160...380 ATE

5. Technical data

MEMDOS E / DX 4..0.156		Size	4	8	15	25²⁾	26¹⁾	50	75^{2) 5)}	76^{1) 5)}	110	150²⁾	156¹⁾	
Capacity at max. pressure ⁴⁾		l/h	4	7.5	15	25	25	48	72	72	107	160	160	
Stroke volume		ml/stroke	2.6				8.5				19			
Max. pressure		bar	10								5	4		
Stroke frequency ⁴⁾		rpm	26	48	95	142	142	95	142	142	95	142	142	
Diaphragm ø		mm	52				64				90			
Stroke length		mm	6				9							
Suction lift		mbar	900				800				700			
max. inlet pressure		mbar	500											
max. ambient temperature ³⁾		°C	40											
Power output E (3~)		W	50					250						
Power output DX (1~)		W	50					120						
Weight Plastic	E	kg	7.4				7.6				10.2			
	DX	kg	8.0				9.2				12.0			
Weight Stainless steel	E	kg	8.1				9.5				18.0			
	DX	kg	8.7				11.1				20.0			

MEMDOS E / DX 160...380		Size	160	200	260²⁾	300	380²⁾
Capacity at max. pressure ⁴⁾		l/h	170	208	263	292	393
Stroke volume		ml/stroke	36.5			51.2	54.5
Max. pressure		bar	10			8	6
Stroke frequency ⁴⁾		rpm	71	95	120	95	120
Diaphragm ø		mm	120			150	
Stroke length		mm	10				
Suction lift		mbar	600			450	
max. inlet pressure		mbar	500				
max. ambient temperature ³⁾		°C	40				
Power output E (3~)		W	370				
Power output DX (1~)		W	250				
Weight Plastic	E	kg	17.0			19.0	
	DX	kg	24.0			26.0	
Weight Stainless steel	E	kg	26.0			32.0	
	DX	kg	33.0			39.0	

1) Special sizes for 60 Hz operation. Delivery capacity and stroke frequency data refer to 60 Hz operation.

2) Not suitable for 60 Hz operation.

3) Max. media temperature 40 °C for PVC dosing head, and 60 °C for PP and stainless steel dosing heads (80 °C for short periods).

Min. media temperature at 0 °C.

4) For 60 Hz operation, values are increased by a factor of 1.2.

5) The pipe size should be no smaller than DN 10, please refer to section 7.1.

Control unit (MEMDOS DX)		Standard version	CSA version
Power supply		95 ... 264 V AC, 48 ... 63 Hz	
Connection		1.8 m cable, 3-wire, 0.75 mm ² Safety plug	1.8 m cable, 3-wire, 0.75 mm ² UL/CSA plug
Power consumption (without motor)		10 W	
ISO class		F	
Protection class		IP 55*	
Max. admissible ambient temperature		40	
Digital display		3-digit display for stroke frequency and level status	
LEDs for functional display		in operation (green)	
		fault (red)	
		external control (green)	
Plastic film keypad		4 keys for programming and operation	
Weight		0.8 kg	
Inputs			
External switch-off		External pump switch-off with potential-free contact (normally closed, N.C.) provided by operating company 3.5 mm jack socket (M12x1 plug optional)	
Level input		Connection of accessories (e.g. suction line with level switch) 5 V DC voltage, pre-alarm and main-alarm, Connection Contact: normally closed, N.C. 3.5 mm jack socket (M12x1 plug optional)	
External control		Pulse input or analogue input	
		RCA socket (M12x1 plug optional)	3-pin socket
	Pulse input	potential-free contact (normally closed, N.C.) provided by operating company	
		5 V DC voltage	
	Pulse length min. 30 ms		
	Multiplication/division of pulses	1 / 2 / 4 / 8 / 16 / 32 / 64	
	Analogue input	0/4...20 mA signal **	
		Working resistance: 150 Ohm	
Outputs			
Warning alarm relay		voltage-free changeover contact, max. 250 V AC, 2.5 A or max. 30 V DC, 2.5 A, Cable connection	

* if connection ports are protected by caps, or standard connectors are inserted.

**1 If several dosing pumps are connected in series with 4... 20 mA control, an additional device (splitter) is necessary.

5.1 Electric motor data

MEMDOS DX		4...50	75...156		160...380	
Standard motor, type		AF 63/4B-7R			EB20RW71G4	EB20RW71K4
Speed	rpm	1360	1390	1650	1410	1680
Voltage	V 1~	230		120	230	120
Nominal current	A	0.7	1.15	2.2	3.3	5.1
Power output	kW	0.05	0.12		0.25	0.25
Frequency	Hz	50		60	50	60
Protection class		IP 55				
ISO class		F				
Overheating protection		integrated temperature switch				

MEMDOS E		4...50	75...156		160...380	
Standard motor, type		AF 63/4B-7R	AF 63/4C-7R		K21R7164	KR21R80K4TPM
Speed	rpm	1400			1430	1400
Voltage	V 3~	230/400				
Nominal current	A	0.86/0.5	1.5/0.9		1.75/1.0	2.8/1.6
Power output	kW	0.05	0.25	0.37	0.55	
Frequency	Hz	50				
Protection class		IP 55				
ISO class		F				
PTC thermistor		optional				

Explosion-proof motors for MEMDOS E

MEMDOS E		4...156	160...380	4...156	160...380	
Type		KPER63K4	KPER71G4	F63CTV/a4	F71CTV/b4	
Explosion protection		increased safety EExellT3		EXdelICT4 pressure-resistant enclosure		
Speed]	rpm	1370		1410	1380	
Voltage	V 1~	230/400				
Nominal current	A	0.83/0.48	1.87/1.08	1.0/0.6	2/1,15	
Power output	kW	0.12	0.25	0.18	0.37	
Frequency	Hz	50				
Protection class		IP 55				
ISO class		F				
PTC thermistor		optional				

5.2 Technical data ATE servomotor MEMDOS E (optional)

Reversible servomotor with self-locking step-down gear. Connections via cable glands. Angle of rotation limited by two internal limit switches.

Servomotor		NK 1510		NK 1510-PMR-NK	
Part No.		79466	79468	79467	79469
MEMDOS E		E4 ... 380			
Voltage		230 V AC, 50/60 Hz	115 V AC, 50/60 Hz	230 V AC, 50/60 Hz	115 V AC, 50/60 Hz
Power consumption		7 VA			
Regulation time	50 Hz	45 s			
	60 Hz	39 s			
Regulation bevel		270° ↔ 0...100%			
Protection class		IP 65			
Ambient temperature		-15 ... +60			
Weight		2.5 kg			
Inputs					
Control		3-point step control		0(4) ... 20 mA	
Working resistance at 0/4...20 mA		-		250 Ω	
Outputs					
Position feedback signal for remote display		0...1000 Ohm, max. 2 W		0(4) ... 20 mA 0(2) ... 10 V	

See the enclosed operating instructions for the ATE servomotor for further technical data.

6. Performance curves

The performance curves refer to water at 20 °C (68 °F) and a suction lift of 0.5 m. The medium (density and viscosity) and temperature cause the delivery rate to change. Dosing pumps must therefore be gauged in litres for the application. At 60 Hz operation, values are increased by a factor of 1.2.

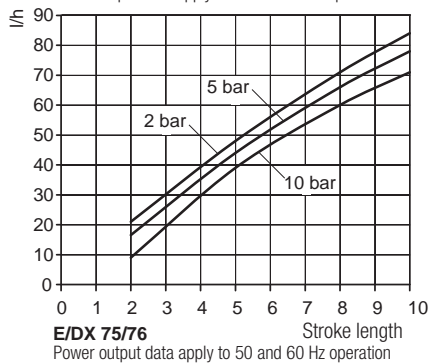
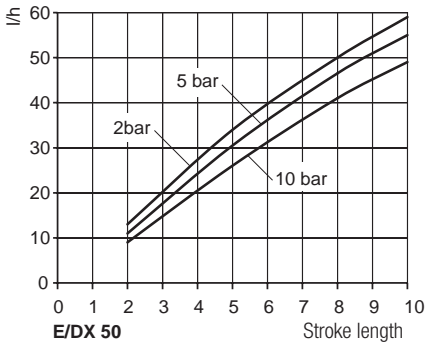
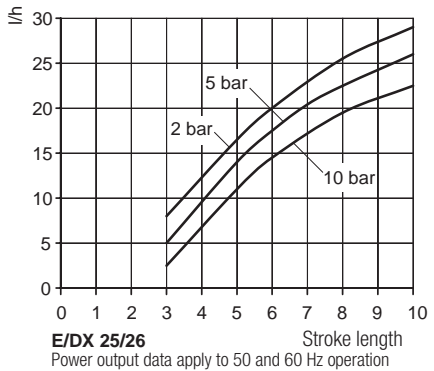
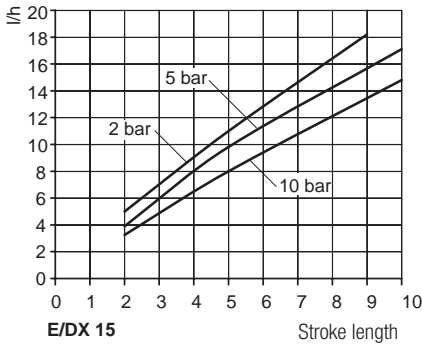
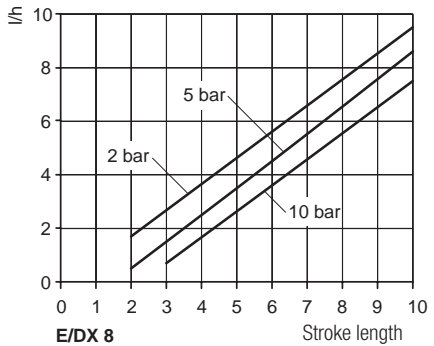
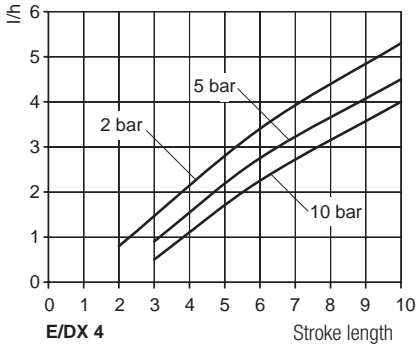

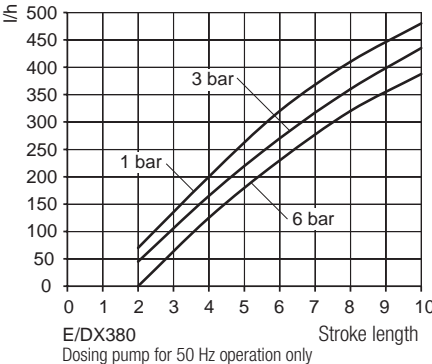
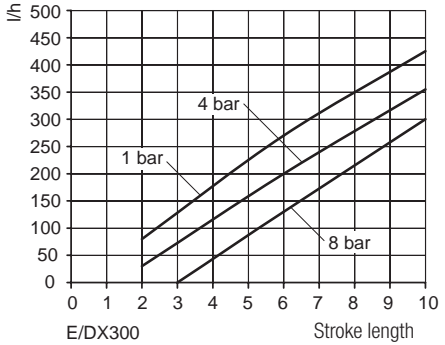
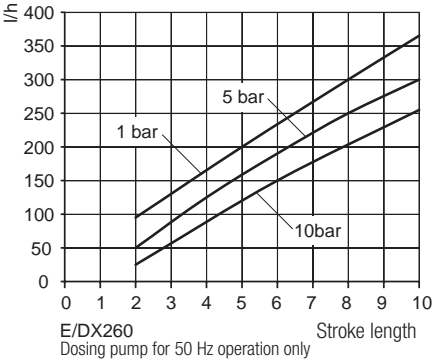
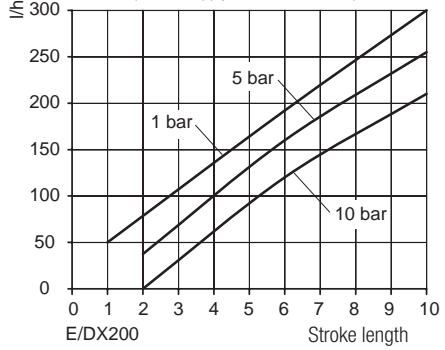
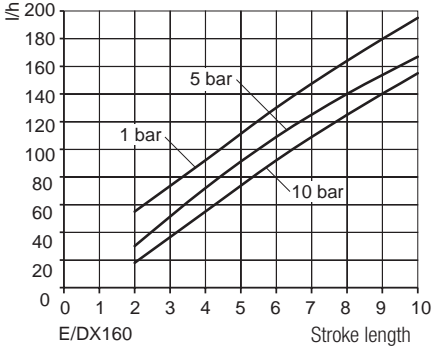
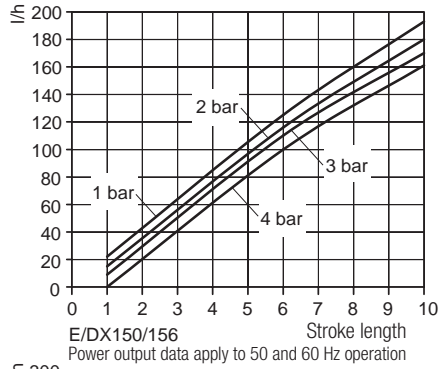
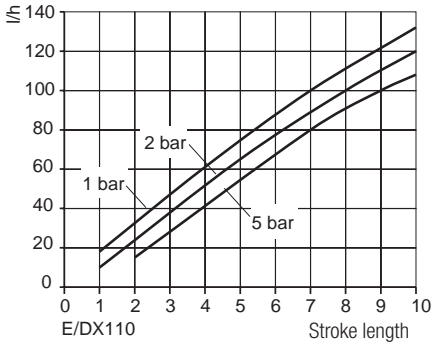

7. Installation

7.1 General information

Local rules and regulations must be taken into account when selecting a dosing pump for designing a system, and for installation and operation. This applies to the selection of the appropriate materials for the dosing pump, the handling of chemicals, and electrical installation.

Before installing the pump in areas with a potentially explosive atmosphere, the dosing pump must be checked to ensure that it meets the minimum requirements set by the applicable explosion protection regulations. For this purpose, the data on the dosing pump rating plate must be compared with the local requirements.

The technical specifications of the dosing pump (section 5) must also be taken into consideration, and the system designed accordingly (e.g. pressure loss for pipe dimensions i.e. nominal diameter and length).

ATTENTION!

For the MEMDOS E/DX 75 and 76, pipe dimension must be at least DN 10. The DN 6 pipe dimension is permissible only for short lines (up to 2 m) and low-viscosity media (<50 mPa s) .



The designer and operating company are responsible for ensuring that the whole system, including the dosing pump, is constructed so that neither system parts nor buildings are damaged in the case of chemical leakage due to the failure of wear parts (e.g. diaphragm rupture) or burst hoses. If the chemical system represents a potential source of danger, the installation must be designed so that no unreasonable consequential damage occurs, even if the dosing pump fails. We therefore recommend installing leakage monitors and collecting pans.

The drain pipe of the dosing head must be visible so that a diaphragm rupture can be detected. Drainage should be able to flow freely downward through the drain pipe.

To increase dosing accuracy and ensure functional reliability, we recommend installing additional valves and accessories. These include back-pressure valves, pressure-relief valves, leakage monitors and low level indicators, as shown in the installation examples.

Always use appropriate tools when installing plastic connecting parts. To avoid damage, never apply excessive force.

IMPORTANT!

Plastic parts (especially PVC parts) can be tightened and loosened more easily by applying lubricant to the thread beforehand (e.g. silicone grease).

Threaded stainless steel parts (e.g. dosing head and valves) must be lubricated before being assembled (e.g. with PTFE spray), in order to prevent seizing.



ATTENTION!

Check the lubricant for compatibility with the chemical.



7.1.1 Installation of MEMDOS E with ATE servomotor

When delivered, the ATE servomotor is already connected to the dosing pump and adjusted. When installing, sufficient installation space of at least 150 mm must be provided in order to allow later maintenance.

The electrical connection of the ATE servomotor must be made according to local regulations and may only be carried out by qualified technical personnel. The wiring diagrams (section 7.5) show the two basic connection variants.

Cable type and cross-section must be chosen according to the motor data.

The cable passage through the housing must be made professionally. We recommend using gland connections with strain-relief clamp. The required protection class must be ensured by professional-standard installation of the electrical connections.



ATTENTION!

Note that the ATE servomotor can only be actuated when the main drive motor of the dosing pump is running. This means that the ATE servomotor must be locked electrically. Otherwise, the adjusting eccentric will suffer excessive wear, or be destroyed.

7.2 Installation location

The installation location of the dosing pump must be easily accessible by operating and service personnel.

ATTENTION!

Ambient temperatures above 40 °C are not permitted. Radiant heat from apparatus and heat exchangers must be shielded so that heat from the dosing pump can be dissipated sufficiently. Avoid exposure to direct sunlight. If the dosing pump is installed outside, provide a roof to protect it from the effects of weather.

Install the pump so that the suction and discharge valves are in vertical position. To ensure stability, the dosing pump must be screwed onto an appropriate surface. The system piping must not exert any force on the connections and valves of the dosing pump. To avoid dosing errors at the end of the process, the dosing pump must be locked electrically and hydraulically.

7.3 Drain pipe

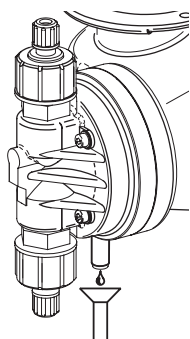

ATTENTION!

Released gases can destroy the dosing pump gear.

Drainage or leakage from the separating chamber must be allowed to flow downward to the collecting pan. The drain pipe must never lead directly back to the medium through the tank cover, otherwise released gases may get into the pump gear. The drain pipe should only lead downward to a gas-free collecting tank, or downward to a collecting funnel, leaving a sufficient gap from the end of the pipe. Leakage can then be returned through the funnel and through the tank cover. This makes it easier to detect any leakages at the gap to the collecting funnel.

ATTENTION!

If a leakage monitor is installed in an area with a potentially explosive atmosphere, the electrical connection must be intrinsically safe. The drive motor must be electrically interlocked to prevent additional medium escaping if a leak occurs.



7.4 Electrical connection of the pump

The electrical connection of the dosing pump must be made according to the local rules and regulations and may only be carried out by qualified technical personnel. Cable type and cross-section of the supply lines must be chosen according to the motor data. The cable passage to the motor terminal box must be made professionally. We recommend using gland connections with strain-relief clamp. The required protection class must be ensured by professional-standard installation of the electrical connections.

For external switch-off of the dosing pump, see paragraph 8.2.



ATTENTION!

Dosing pumps with explosion-proof motors must be installed and commissioned by specialists qualified to work with equipment intended for use in potentially explosive atmospheres. The user is responsible for ensuring that explosion-proof motors are connected correctly. Both the motor and dosing pump must be grounded to prevent electrostatic discharges.



DANGER!

Fire hazard. Shock wave: parts may fly off and cause fatal injury. MEMDOS DX must never be used in areas with a potentially explosive atmosphere. The electrical connection of the dosing pump must be made according to the local rules and regulations and may only be carried out by qualified technical personnel.

NOTICE!

The dosing pump must be plugged into a grounded power outlet. The 230 V AC version of the MEMDOS DX is connected by a safety plug. The 115 V AC version is equipped with a UL/CSA plug.

NOTICE!

Signal cables must not be laid parallel to high-voltage current lines or mains cables. Lay supply and signal lines in separate channels. An angle of 90° is required at line crossings. If signal lines are longer than 2 m, shielded cables must be used.

**ATTENTION!**

To avoid premature wear of the gear, always ensure the correct rotation direction of the motor: counter-clockwise (to the left), looking toward the fan wheel.

7.4.1 Drive motor connection**IMPORTANT!**

Note the data on the motor rating plate



Connection	MEMDOS	Phases	Motor supplier	Note
	E 4...156, E 160...380	3~	All	Y-connection (Standard)
	E 4...156, E 160...380	3~	All	Delta connection

MEMDOS E three-phase motors

Connection	MEMDOS	Phases	Motor supplier	Note
	E 4...156	1~	ATB	
	E 4...156	1~	EMG	230 V AC or 120 V AC (CSA)

Connection	MEMDOS	Phases	Motor supplier	Note
	E 160...380	1~	VEM	

MEMDOS E alternating current motors

Connection	MEMDOS	Motor supplier
	DX 4...156	ATB
	DX 4...156	EMG
	DX 160...380	VEM

MEMDOS DX alternating current motor

MEMDOS DX control unit		Standard version	CSA version
L1	RUN	BR (brown)	BK (black)
L2	STOP	BK (black)	RD (red)
N		BU (blue) or GY (grey)	WH (white)
PE		GN/YE (green/yellow)	GN/YE (green/yellow)

Connection between MEMDOS DX control unit and motor

7.5 Wiring diagrams for ATE servo motor for stroke length adjustment

See the accompanying operating instructions for the ATE servomotor.

7.6 Level control

If a level control is connected, the jack plug has to be covered by a plastic sleeve in order to maintain the protection class. The required sleeve is part of the level control (also in combination with a suction line).

With the level control connected, the dosing pump stops if the chemical level in the supply tank is low, in order to prevent air bubbles from entering the suction line and the dosing head. The red LED is lit. As soon as the level contact closes again, the dosing pump restarts.

The level sensor must be designed as a max. N.O. contact.

MEMDOS is equipped with a 2-stage level control. When the first contact breaks (pre-alarm), the red LED begins to flash. The dosing pump continues to operate. The warning alarm relay is actuated. The dosing pump only stops when the second contact breaks (main alarm). The red LED is lit continuously.

The "level pre-alarm" function is not available if a 2-pin connector and one level switch are used.

NOTICE!

A dummy plug (part no. 29115) must be attached if a level switch is not connected. The dosing pump is delivered with a dummy plug already attached. If a level switch is to be connected, the dummy plug has to be removed before inserting the jack plug.



7.7 Back-pressure and safety valves

Back-pressure valves are used to optimise the dosing process. They are used:

- to increase the dosing accuracy in the presence of fluctuating back pressures.
- when the dosing lines are long, in order to prevent excess delivery, since the accelerated medium continues moving due to its own inertia even after the delivery stroke has ended.
- to prevent siphoning, if the supply pressure is higher than system pressure.

Pressure-relief and safety valves are used for overload protection of the dosing pump and the associated valves and lines. They prevent inadmissible pressure rises in the delivery side system of the dosing pump; for example, if shutoff valves close while the pump is running, or if the injection nozzle is clogged.

The PENTABLOC is a combination valve and performs the functions of a back-pressure valve and a safety valve, among others. It also integrates functions such as anti-siphoning, pressure relief and dosing control.

7.8 Injection nozzle installation

Injection nozzles are used to inject the metered medium into the main flow, while at the same time acting as non-return valve. The injection nozzle is usually mounted from the top into the main line. Mounting from below is recommended only for media that have a tendency to crystallise, in order to prevent air bubbles from being trapped in.

For media that tend to contaminate the injection nozzle, we recommend installing an injection nozzle that can be shut off and removed for maintenance purposes.

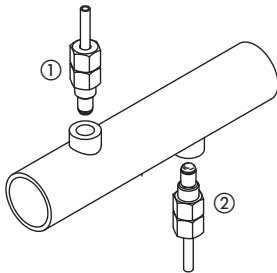

① Injection nozzle mounted from above. ② Injection nozzle mounted from below (for media that tend to crystallise)

7.9 Installation example

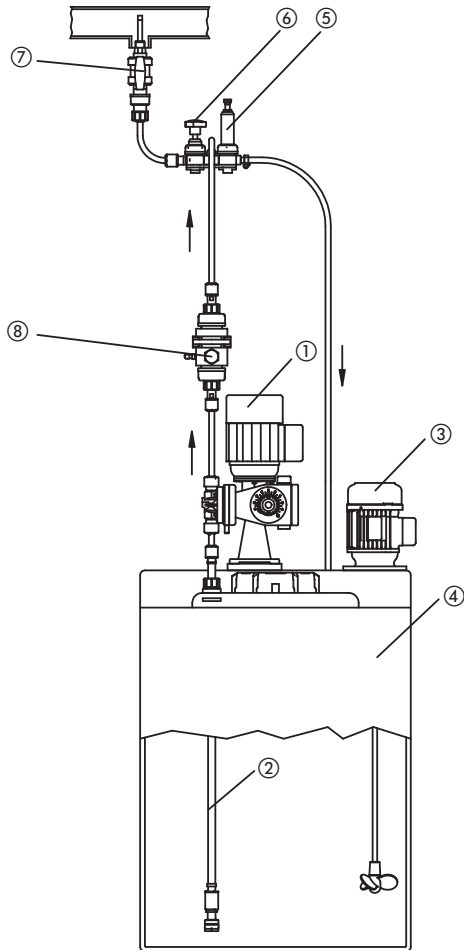

- ① Dosing pump
- ② Suction line
- ③ Electric agitator
- ④ Tank
- ⑤ Pressure-relief valve
- ⑥ Diaphragm shutoff valve
- ⑦ Injection nozzle
- ⑧ Pulsation damper

8. Operation

8.1. Stroke length adjustment

ATTENTION!

The stroke length should not be adjusted while the dosing pump is stopped!

Proceed as follows to adjust the stroke length:

1. Turn the mounting screw on the adjusting knob counterclockwise (to the left) to loosen it.
2. Set the stroke length to the required value according to the performance curves (section 6).
3. Retighten the mounting screw, without changing the stroke length setting.

8.2 MEMDOS DX operating elements

The **operating panel has two green LEDs for operation and external control, one red LED for alarm, one 3-digit multifunctional display and four operator keys.**

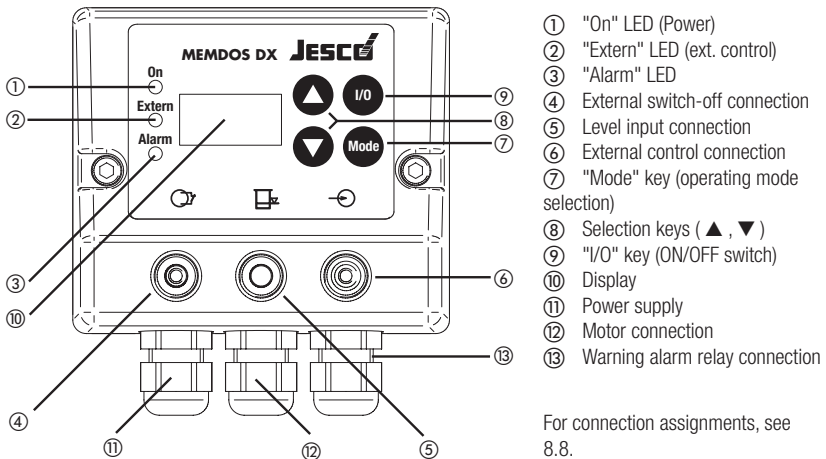

8.3 Switching on/off

The dosing pump is switched on/off using the I/O key. When disconnected, the display shows OFF. When the contact is opened for external switch-off, the dosing pump is also switched off. The "Extern" LED is also lit.

ATTENTION!

The dosing pump may be switched on/off remotely only by using the external switch-off - not by using the power supply.

8.4 Operating mode selection

The following operating modes can be set by simultaneously pressing the "Mode" and ▲ or ▼ keys:

- Manual control (internal operation)
- Pulse control (external cycle)
- Analogue control (control signal 0/4...20mA)

In the as-delivered state, the dosing pump is set to manual control.

Key	Display	Description	Key	Display	Description
Mode +	▼ INT	Manual control	Mode +	▼ 64.1	Pulse control
	▼ 1.64	Pulse control		▼ 32.1	
	▼ 1.32			▼ 16.1	
	▼ 1.16			▼ 8.1	
	▼ 1.8			▼ 4.1	
	▼ 1.4			▼ 2.1	
	▼ 1.2			▼ 1.1	
		▼ 0.20			

Manual control

The dosing pump delivers a constant flow of chemical per unit time, regardless of the process.

To set this operating mode, proceed as follows:

1. Press the "Mode" and ▲ or ▼ keys simultaneously until INT is displayed.
2. Release the "Mode" key. The current stroke frequency is displayed (strokes/min)
3. Use the ▲ and ▼ keys to change the stroke frequency.

Pulse control

The dosing pump delivers a constant flow of chemical per input pulse. Up to 64 pulses are buffer-stored if the pulse rate exceeds the processing speed. To set the pulse multiplication/division, simultaneously press the "Mode" and ▲ or ▼ keys until one of the following values is displayed:

- for a ratio of 1:1, i.e. the dosing pump executes one dosing stroke after each pulse,
- 1.2 to 1.64 for pulse multiplication or
- 2.1 to 64.1 for pulse division

The "Extern" indicator is lit.

Settings for pulse multiplication and division: 1, 2, 4, 8, 16, 32 and 64.

Example	
1.64	The dosing pump executes 64 dosing strokes after each pulse.
64.1	The dosing pump executes one dosing stroke after 64 pulses.

Analogue control

The dosing pump doses proportionally to the input signal. To set the operating mode, press the "Mode" and ▲ or ▼ keys simultaneously until one of the following values is displayed:

- 0.20 for 0...20 mA signal or
- 4.20 for 4...20 mA signal

When the "Mode" key is released, the stroke frequency corresponding to the current is displayed. The "Extern" indicator is lit. If the current is greater than 20 mA (display: OVL) or less than 4 mA (display: E-I), the alarm indicator is lit, the warning alarm relay switches and the dosing pump stops. The stroke frequency of the dosing pump is proportional to the input signal.

8.5 Alarm

The dosing pump allows monitoring of the dosing process. An alarm is indicated visually on the display and transmitted by the warning alarm relay.

	Alarm LED	Alarm relay	Pump	Display
Level pre-alarm	flashes	switches	continues to operate	Number of strokes
Level main alarm	is lit	switches	stops	E - L

Internal error

The dosing pump carries out a self-check, which switches off the pump if no stroke has been carried out two seconds after motor start-up (e.g. if back pressure is too high) or if the proximity switch (stroke sensor) does not respond (display E-2). The alarm is reset by pulling out the mains plug.

The functions of the LEDs and built-in warning alarm relay are shown in the following table:

Condition	LED 1 ON	LED 2 Extern	LED Alarm	Warning alarm relay			Display
				RO	RW	R1	
Power supply absent				closed			-
Dosing pump running	⊗				closed		Number of strokes
Dosing pump off (by ON/OFF switch)				closed			OFF
Dosing pump off (by external contact)		⊗		closed			OFF
Level pre-alarm	⊗	*)	flashes	closed			Number of strokes
Level main alarm	⊗	*)	⊗	closed			E - L
Dosing pump fault (proximity switch, stroke sensor)	⊗	*)	⊗	closed			E - 2
Dosing pump fault (current < 4 mA)	⊗		⊗	closed			E - I

*) LED 2 is lit in operating modes 1.1 - 1.64; 0...20 mA and 4... 20 mA

8.6 Other settings

8.6.1 Max. number of strokes

Press and hold the "Mode" and "I/O" keys while applying the voltage, and set the maximum pump stroke frequency using keys ▼ and ▲. When the "Mode" key is released, normal operation starts.



8.6.2 Warning alarm relay connection







Relay not activated in case of fault or OFF: When voltage is applied, press and hold "Mode" and ▲ keys. Display: "RE0". Relay activated in case of fault or OFF: When voltage is applied, press and hold "Mode" and ▼ keys. Display: "RE1".

8.7 Factory setting

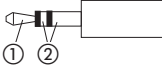
- The initial status of MEMDOS DX is "OFF".
- Depending on the technical specifications, the maximum stroke frequency is preset (see section 5).
- In case of a fault or "OFF", the warning alarm relay is not activated.

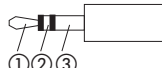
8.8 Connections and cable assignments

MEMDOS DX control unit			Standard version	CSA version		
⑫	L1 RUN	Motor	BR (brown)	BK (black)		
	L2 STOP		BK (black)	RD (red)		
	N		BU (blue) or GY (grey)	WH (white)		
	PE		GN/YE (green/yellow)	GN/YE (green/yellow)		
⑪	L	Power supply 230 V AC, 50/60 Hz or 120 V AC, 50/60 Hz	BR (brown)	BK (black)		
	N		BU (blue) or GY (grey)	WH (white)		
	PE		GN/YE (green/yellow)	GN/YE (green/yellow)		
⑬	RO Break contact	Warning alarm relay (1.5 m cable)			BR (brown)	RD (red)
	Rw Changeover contact				BU (blue) or GY (grey)	WH (white)
	R1 Make contact				BK (black)	BK (black)
			RO RW R1 Fault	RO RW R1 Operation		

Connection	Connector	Housing	Cable						
④ External switch-off	3.5 mm jack plug	Socket	 <p>① ②</p> <p>2.5 m 3-wire (cable included in delivery)</p> <table border="1"> <tr> <td>① Input (+)</td> <td>RD (red)</td> </tr> <tr> <td>② Ground (GND)</td> <td>BK (black) / WH (white)</td> </tr> </table>	① Input (+)	RD (red)	② Ground (GND)	BK (black) / WH (white)		
			① Input (+)	RD (red)					
	② Ground (GND)	BK (black) / WH (white)							
	M12 x 1, A coded (optional)	Plug	 <p>1 = input (+) BN (brown)</p> <p>2 = ground (GND) WH (white)</p>						
⑤ Level input	3.5 mm jack plug	Socket	 <p>① ② ③</p> <p>Manufacturer's accessories</p> <table border="1"> <tr> <td>① Main alarm</td> <td>RD (red)</td> </tr> <tr> <td>② Pre-alarm</td> <td>WH (white)</td> </tr> <tr> <td>③ Ground (GND)</td> <td>BK (black)</td> </tr> </table>	① Main alarm	RD (red)	② Pre-alarm	WH (white)	③ Ground (GND)	BK (black)
			① Main alarm	RD (red)					
	② Pre-alarm	WH (white)							
	③ Ground (GND)	BK (black)							
M12 x 1, A coded (optional)	Plug	 <p>1 = pre-alarm BN (brown)</p> <p>2 = main alarm WH (white)</p> <p>3 = ground (GND) BU (blue)</p>							
⑥ External control	RCA	Socket	 <p>① ②</p> <p>1.5 m 2-wire (cable included in delivery)</p> <table border="1"> <tr> <td>① Input (+)</td> <td>BN (brown)</td> </tr> <tr> <td>② Ground (GND)</td> <td>WH (white)</td> </tr> </table>	① Input (+)	BN (brown)	② Ground (GND)	WH (white)		
			① Input (+)	BN (brown)					
	② Ground (GND)	WH (white)							
	CSA version	Plug	 <p>1.5 m, 3-wire (cable included in delivery)</p> <table border="1"> <tr> <td>1 = input (+)</td> <td>BN (brown)</td> </tr> <tr> <td>2 = -</td> <td>BK (black)</td> </tr> <tr> <td>3 = ground (GND)</td> <td>BU (blue)</td> </tr> </table>	1 = input (+)	BN (brown)	2 = -	BK (black)	3 = ground (GND)	BU (blue)
1 = input (+)	BN (brown)								
2 = -	BK (black)								
3 = ground (GND)	BU (blue)								
M12 x 1, B coded (optional)	Plug	 <p>1 = ground (GND) BN (brown)</p> <p>2 = pulses WH (white)</p> <p>3 = pulses BU (blue)</p> <p>4 = ground (GND) BK (black)</p>							

NOTICE!

The protection class of the control unit is only ensured if the connection ports are protected by caps or the standard connectors are inserted.



9. Start-up



CAUTION!

The personal protective equipment specified by the applicable accident prevention regulations must be worn whenever working on the dosing pump/system.



Protective clothing



Protective gloves



Protective goggles

1. All the work described in "Installation" (section 7) must be carried out before starting the dosing pump. The safety instructions (section 1) must also be observed.
2. Fill the dosing pump with the oil supplied. For oil grade and quantity, see paragraph 11.1.
3. The MEMDOS E dosing pump is switched on by a control to be installed externally. The MEMDOS DX has its own control unit. Electrical connection and the control types are explained in section 8, MEMDOS DX operating controls.
4. The manual capacity adjustment should be set to maximum stroke for better priming. During the initial priming, there should be no back pressure. For this purpose, we recommend installing a relief valve on the discharge side of the dosing pump.
5. If a priming aid has been installed, this must be filled with chemical first. If the dosing pump does not prime, switch off the dosing pump, unscrew the discharge valve and fill the dosing head with fluid. If non-hazardous, the medium itself can be used; otherwise use a neutral medium that will not disturb the process. (In many cases, water can be used.)



WARNING!

Chemical may spray out. This may lead to chemical or other burns. Ensure that the discharge line is depressurised before disconnecting.

Then, mount the discharge valve again, switch on the dosing pump and start priming. (A priming aid is recommended. See installation examples.)

6. If there is a vent valve integrated in the dosing head or installed as a separate fitting, open it while the dosing pump is operating until fluid comes out. Then close it again. In the case of outgassing media, allow the fluid to flow off continuously (about 1 drop per 1 - 3 strokes). The escaping fluid flows through a hose back into the tank.
7. When correct operation has been established, set the desired delivery rate using the adjusting knob (see section 8.1) or the remote control adjustment. For an initial approximation, refer to the performance curves (section 5).



NOTICE!

Depending on the installation and the chemicals used, these values may differ and must be checked under operating conditions.

8. The manufacturer of the dosing equipment is not responsible for damage due to excessive or insufficient flow rates at the dosing pump or incorrect or faulty installation of peripheral fittings.

9.1 Start-up of MEMDOS E with ATE servomotor

Switch on the main drive motor of the dosing pump. An electrical interlocking system then allows ATE drive adjustment. To check the direction of rotation, send short control pulses to the ATE servomotor. If the direction of rotation is wrong, adjust its direction as described in the ATE servomotor operating instructions. To check the limit stop of the integrated limit switches, the ATE servomotor must be moved to the end position. The factory-set angle of rotation is 270°. If required, the maximum delivery rate can be changed by limiting the angle of rotation. To do this, the trigger cams of the limit switches are moved.

10. Shutdown

Before starting any maintenance or before long downtimes, drain the chemical from the dosing pump and rinse it thoroughly with a neutral medium.

CAUTION!

Excess chemical must be disposed properly. Follow the applicable accident prevention regulations, and wear personal protective equipment.



Protective clothing



Protective gloves



Protective goggles

CAUTION!

The dosing pump must be disconnected from the power supply and secured to prevent it being restarted.



CAUTION!

Before disconnecting the discharge line from the pump discharge valve, release the pressure so that chemical does not spray out.



To drain the dosing head, it is advisable to unscrew the discharge and suction valves.

10.1 Disposal of old equipment

If the equipment is being disposed of, it should be washed thoroughly. Residual chemicals should be disposed of properly. The equipment was manufactured in accordance with the ROHS guideline and the waste electrical equipment legislation. The manufacturer will take care of disposal if the equipment is returned free of charge. It should not be disposed of as domestic waste!

Device revision

This operation manual applies to following devices:

Device	Revision
MEMDOS E	8/2001
MEMDOS DX	8/2001

It contains all the technical information required for installation, start-up and maintenance. Should you have any questions or require further information regarding this operation manual, please contact the manufacturer or their official national representative.

11. Maintenance

These dosing pumps are produced to the highest quality standards, and have a long service life. Nevertheless, some of their parts are subject to wear due to operation (e.g. diaphragms, valve seats, valve balls). Regular visual inspections are therefore necessary in order to ensure a long operating life. Periodic maintenance will protect the dosing pump from operation interruptions. The manufacturer recommends maintenance once per year, provided the local regulations do not specify more frequent maintenance.

11.1 Lubrication

The MEMDOS E/DX diaphragm dosing pump requires little maintenance. The dosing pump gear is lubricated with gear oil of viscosity class ISO-VG460 according to DIN 51519 (corresponds to SAE 140 according to DIN 51512). The first filling, which is supplied with the product, is to be replaced after 5,000 operating hours or 1 year, whichever comes first. Further oil changes should be conducted after 10,000 operating hours or 2 years, whichever comes first. The filling capacity is about 0.25 l for gears of sizes up to MEMDOS E/DX 156 and about 0.7 l for gears of sizes up to MEMDOS E/DX 380. The actual quantity of gear oil required can be determined by checking the min./max. marks on the oil dipstick.



ATTENTION!

MEMDOS DX: To avoid damage to the approximation initiator, the dosing pump must be switched off before taking out the oil dipstick.

11.2 Maintenance of the bearings

The upper bearing of the pinion shaft is a sealed and permanently lubricated ball bearing. In the Size I MEMDOS E/DX (up to E/DX 150), this function is also performed by the drive side motor bearing. The other roller bearings in the gearing, and the plain bearings of the diaphragm rod, are lubricated by the gear oil. The oil also performs a heat dissipation function.

All bearings must be examined for wear after 10000 hours of operation. The service life of the roller bearings depends on the applied loads.

11.3 Maintenance of the ATE servomotor (optional)

The ATE servomotor is given permanent lubrication at the factory. Nevertheless, regular inspections are recommended if the drive is operated in tough operating conditions, for example in high ambient temperatures or continuous operation.

11.4 Diaphragm replacement

CAUTION!

Chemical may spray out. This may lead to chemical or other burns. The dosing pump must always be depressurised and rinsed with water or a suitable medium before starting any work on the dosing pump.



① Dosing head with discharge and suction valve

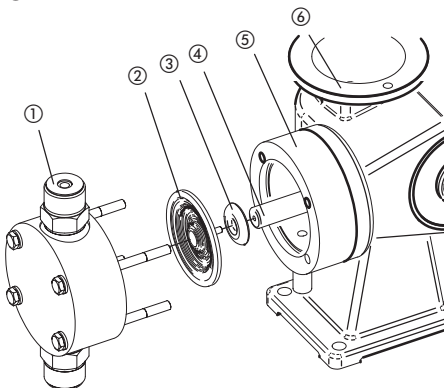

- ② Diaphragm
- ③ Support plate (only E/DX 50,75,76)
- ④ Diaphragm rod
- ⑤ Diaphragm flange
- ⑥ Gear housing

The diaphragm can be replaced as follows:

1. The delivery rate of the dosing pump is set to zero while the motor is running.
This moves the diaphragm to the front end position.
2. Switch off the pump.
3. The head is removed using an appropriate tool. (see Fig. 1)
4. Grasp the edge of the diaphragm and turn it to the left. On the E/DX 50, 75, 76, the support plate located behind the diaphragm is also removed.

IMPORTANT!

Before fitting a new diaphragm, the area around the diaphragm flange and support plate must be cleaned to remove any chemicals, otherwise these might corrode the back of the diaphragm. (see Fig. 2)

5. If present, the support plate is pushed onto the threaded sleeve with the curved side facing towards the diaphragm. (see Fig. 3)
6. The new diaphragm is turned clockwise until it is screwed securely into the diaphragm rod (grease the thread). This causes the flat side of the support plate (if present) to be pressed against the end of the diaphragm rod.
7. The dosing pump stroke is now set to maximum while the motor is running. Switch off the motor. The diaphragm is now seated in the groove of the diaphragm flange.
8. Fit the dosing head at the front. Tighten the screws alternately, e.g. top left – bottom right – top right – bottom left. (see Fig. 4). For the required tightening torque, see table 11.1.

IMPORTANT!

The diaphragm will not be sufficiently sealed if the tightening torque is too low. The dosing head may be damaged if the tightening torque is too high.

9. After connecting the dosing lines, the dosing pump is started as described in "Start-up" (section 9).
10. If the diaphragm becomes worn with unusual frequency, try to determine the cause. For the possible causes, please refer to "Troubleshooting" (section 14).

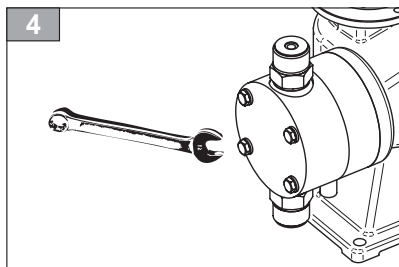
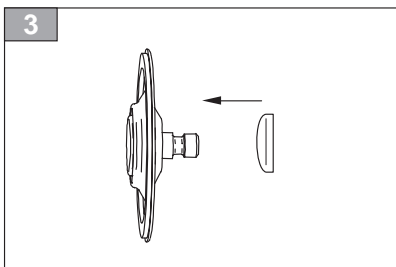
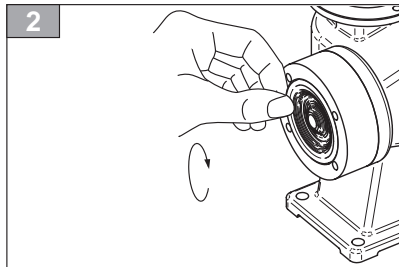
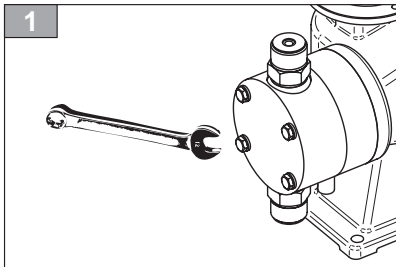

Diaphragm Ø	Torque (+/- 10%)
52	125 Ncm
64	2 Nm
90	6 Nm
120	6 Nm
150	10 Nm

Table 11.1: Required tightening torque for dosing head screws

11.5 Valves

The dosing pump valves must be cleaned regularly.

NOTICE!

When screwing the valves back into the dosing head, note the tightening torque of 2 Nm \pm 20 %.

CAUTION!

Chemical may spray out. This may lead to chemical or other burns. The dosing pump must always be depressurised and rinsed with water or a suitable medium before starting any work on the dosing pump.

NOTICE!

Dirty valves will affect the dosing accuracy.

DN4 valves

DN4 valves are pre-assembled, and can be unscrewed from the dosing head as a single unit. To disassemble the valves, use a screwdriver with a 10 mm bit.

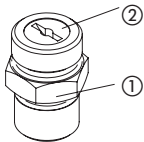

- ① Valve body
- ② Screw-in valve plug

Valves DN 4, MEMDOS E/DX 4..0.26

Double-ball valves

Discharge valve

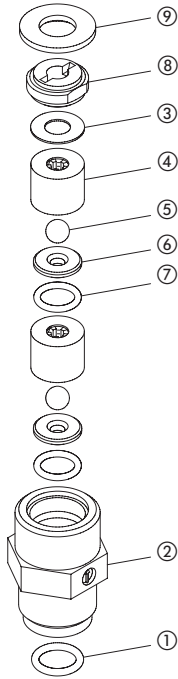

Suction valve

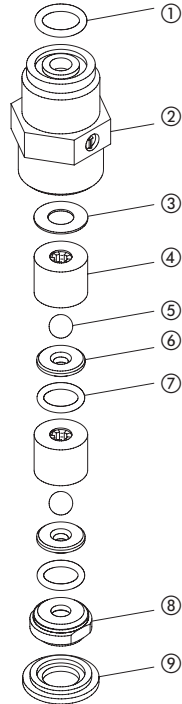

Spring-loaded valves

Discharge valve

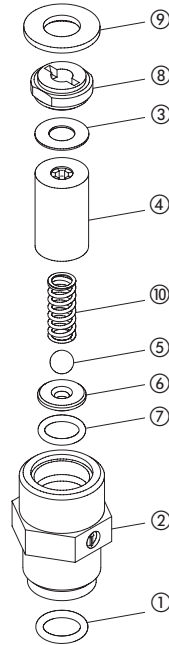

Suction valve

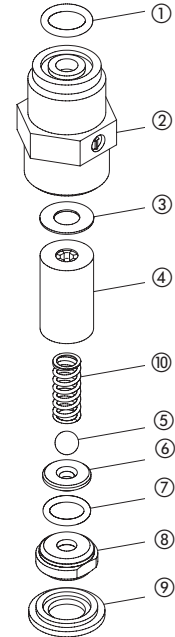

- ① * O-ring
- ② Valve body
- ③ * Flat gasket
- ④ Ball guide
- ⑤ * Valve ball
- ⑥ * Valve seat
- ⑦ * O-ring
- ⑧ Valve plug
- ⑨ * Gasket
- ⑩ * Pressure spring

* included in the spare parts set.

Valves DN 6, MEMDOS E/DX 50..0.76

Double-ball valves

Discharge valve

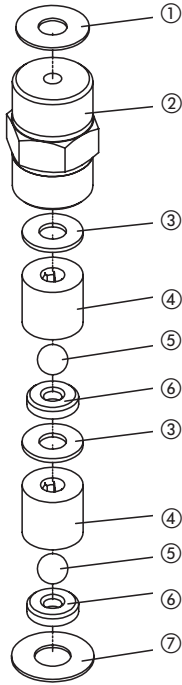

Suction valve

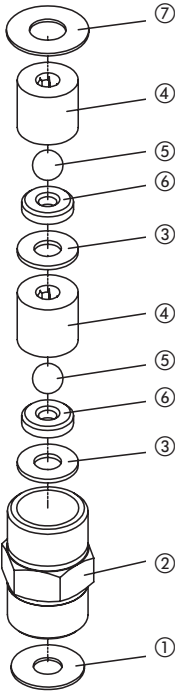

Spring-loaded valves

Discharge valve

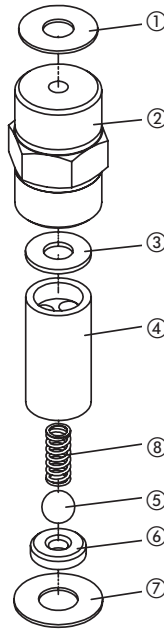

Suction valve

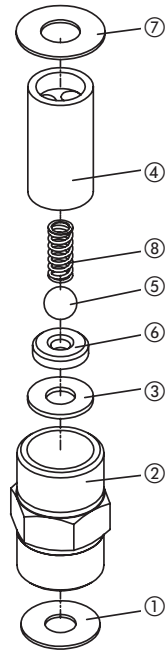

- ① * Flat gasket
- ② Valve body
- ③ * Flat gasket
- ④ Ball guide
- ⑤ * Valve ball
- ⑥ * Valve seat
- ⑦ * Flat gasket
- ⑧ * Pressure spring

* included in the spare parts set.

Valves DN 10, MEMDOS E/DX 160...380

Double-ball valves

Discharge valve

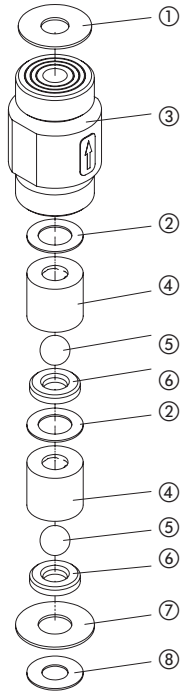

Suction valve

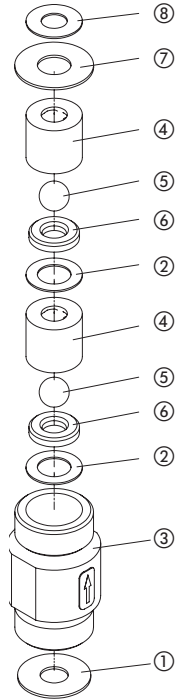

Spring-loaded valves

Discharge valve

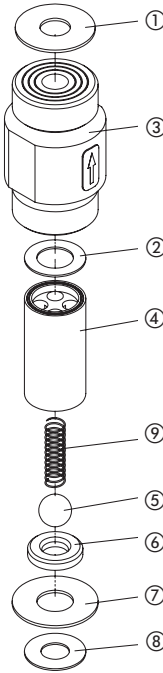

Suction valve

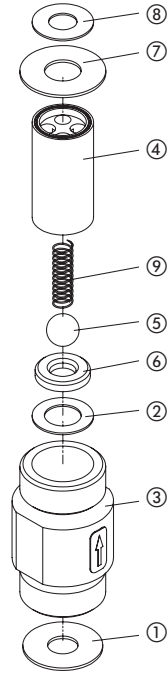

- ① * Flat gasket
- ② * Flat gasket
- ③ Valve body
- ④ Ball guide
- ⑤ * Valve ball
- ⑥ * Valve seat
- ⑦ * Flat gasket
- ⑧ * Flat gasket
- ⑨ * Pressure spring

* included in the spare parts set.

12. Explosion-proof dosing pumps (ATEX)

12.1 General

The explosion-proof version of the MEMDOS E dosing pump is an electric motor-driven, explosion-proof diaphragm dosing pump of equipment category 2, group II.

In combination with an explosion-proof motor (Ex II 2 G E Ex e II T3 or Ex II 2 G E Ex d/de IIB/IIC T4) it is used for dosing fluids Zone 1 hazardous areas. The dosing pump carries the Ex mark "Ex II 2 G c k T4 03 ATEX D085".



ATTENTION!

The dosing pump is not intended for dosing gaseous media or solids.



DANGER!

Fire hazard. Shock wave: parts may fly off and cause fatal injury. MEMDOS DX must never be used in areas with a potentially explosive atmosphere.

12.2 Special conditions

The minimum requirements for the zone classification must be ensured if using the dosing pump in areas with a potentially explosive atmosphere. The dosing pump itself and the motor must meet the minimum requirements.

12.3 Dosing of flammable media

If dosing flammable fluids, all metal parts in the suction and discharge pipes must be grounded to prevent electrostatic discharge.

Stainless steel is recommended for the dosing head.

Dosing pumps with diaphragms more than 90 mm in diameter are equipped with special conductive diaphragms to prevent static charging. When obtaining replacement parts, order original diaphragms only.

13. Troubleshooting

Problem	Possible cause	Remedy
Dosing pump not delivering or output too low	Valves leaking or blocked	Clean the valves and vent the dosing pump. See also "Start-up" Tighten the screw connections.
	Valves incorrectly installed	Reassemble the valves. Ensure that the valve balls are located above the valve seats.
	Suction valve or suction line leaking or blocked	Clean or seal the suction line.
	Suction lift too high	- Set the dosing pump at the inlet. - Install the pulsation damper on the suction side. - Install a priming aid.
	Viscosity too high	- Install spring-loaded valves. - Increase the pipe diameter. - Use the special dosing head. >> Contact manufacturer
No stroke movement	Dosing pump set to zero stroke	Set the stroke length adjusting knob correctly.
	Diaphragm return spring broken	Replace the spring.
	Power supply interrupted	Switch on power supply.
Dosing pump delivery rate too high	Suction side pressure too high (pump siphoning)	Install a back-pressure valve on the discharge line.
Diaphragm cracks frequently	Diaphragm not screwed up to the end stop on the diaphragm rod	Screw a new diaphragm up to the end stop. On E/DX 50...76, the support plate must be clamped firmly between diaphragm and diaphragm rod.
	System back pressure too high (measured at discharge connection of dosing pump)	Inspect the system. Clean blocked injection nozzle. Install pulsation dampers to reduce pressure spikes if pipes are too long. Check that safety valves are working (see installation example).
	Media sediment in dosing head	Clean the dosing head.
Dosing pump very noisy	Roller bearing defective	Replace the roller bearing.
	No oil in the gearing, or too little	Top up the oil as described in "Maintenance".
Motor hums and does not start.	Wrongly connected	Check electrical wiring.
	Capacitor defective, wrong size or connected incorrectly	Connect the capacitor correctly or replace.
	Pressure too high	Check the process.
Alarm states indicated by red LEDs on the display	Level pre-alarm Level main alarm Internal error	Check the functions as described in section 8 (MEMDOS DX operation).
Pump switches off by itself.	Pump inadvertently disconnected from power supply.	Use only an external switch-off to switch the pump on/off. See paragraph 7.4 and 8.2

If the problem cannot be solved with the above remedies, please return the dosing pump to the factory or contact our After-Sales Service for further assistance. Repairs will be carried out immediately.

14. Spare parts

Use the manufacturer's original spare parts. Wear parts are available for the MEMDOS E/DX in spare parts sets.

	Spare parts	Description	E/DX 4...26	E/DX 50...76
⑧	Dosing head with screws	PVC	34882	34873
		PP	35143	35117
		PVDF	34898	on request
		Stainless steel	34899	34901
		other materials	on request	
⑨	Diaphragm	PTFE coated	81464	81465
⑩	Support plate		-	28977
⑪	Control unit (MEMDOS DX)	EU version	34897	
		CSA version	35187	

MEMDOS Size 1

	Spare parts	Description	E/DX 110...156	E/DX 160...260	E/DX 300...380
⑧	Dosing head with screws	PP	34979	23722	34953
		Stainless steel	32890	23728	34952
		other materials	on request		
⑨	Diaphragm	PTFE coated	81466	81467	81468
		Conductive PTFE for ATEX version	81796	81793	81794
⑪	Control unit (MEMDOS DX)	EU version	34897		
		CSA version	35187		

MEMDOS Size 2

Spare parts sets MEMDOS E/DX 4...26

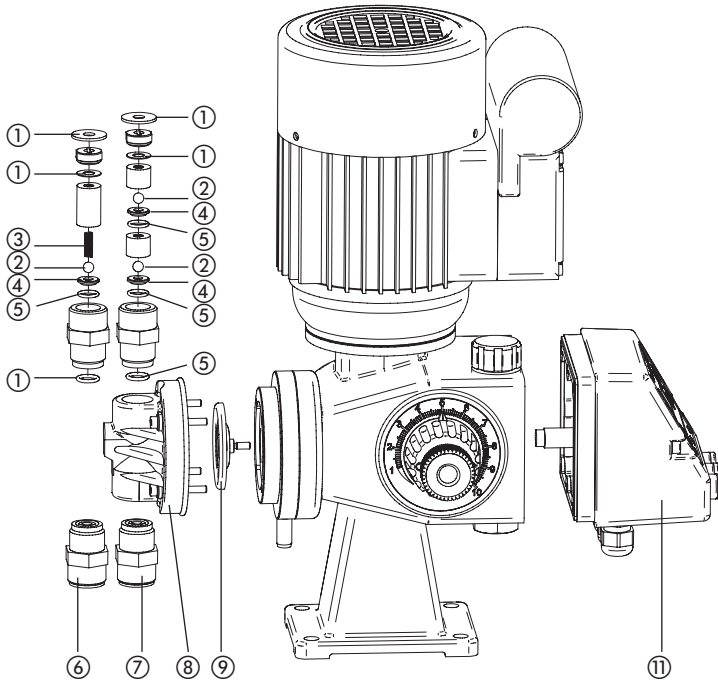

Spare parts sets for valves			
Consisting of:	Material	Double-ball valve	Spring-loaded valve
① Flat gaskets	PVC / Glass / FPM	29750	37336
② Valve balls	PVC / Glass / EPDM	33698	37337
③ * Springs	PP/ Glass / FPM	27750	37336
④ Valve seats	PP/ Glass / EPDM	33698	37337
⑤ O-rings	PVDF / PTFE / PTFE	35572	37341
⑨ Diaphragm	PVDF / PTFE / FPM	33856	37338
* spring-loaded valve only	Stainless steel / PTFE	29751	37339

Complete valves for MEMDOS E/DX 4...26				
Material	⑦ Double-ball valve		⑧ Spring-loaded valve	
	Suction valve	Discharge valve	Suction valve	Discharge valve
PVC / Glass / FPM	20890	20891	25087	25088
PVC / Glass / EPDM	33497	33498	33499	33500
PP/ Glass / FPM	35605	35606	35262	35263
PP/ Glass / EPDM	34647	34648	34733	34809
PVDF / PTFE / PTFE	28111	28112	29385	29384
PVDF / PTFE / FPM	33703	33704	34370	34371
Stainless steel / PTFE	24029	24030	25089	25090

Spare parts sets MEMDOS E/DX 50..0.76

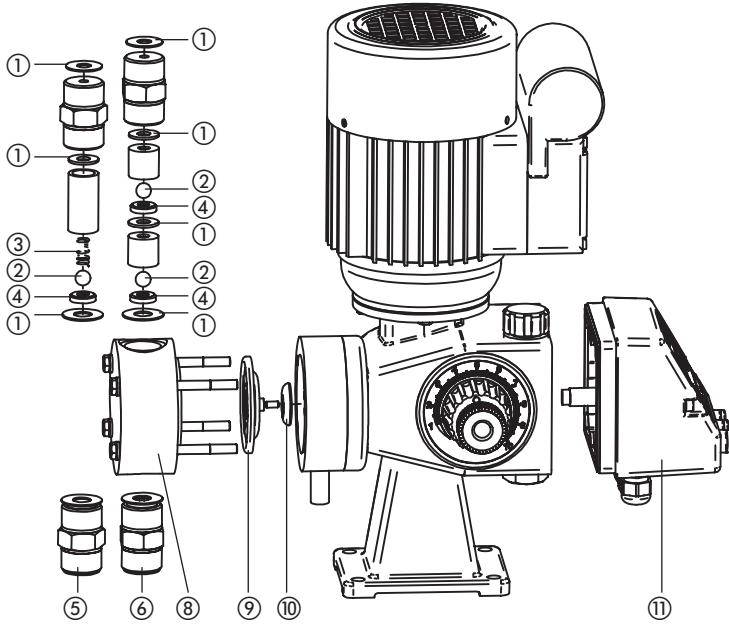

Spare parts sets for valves			
Consisting of: ① Flat gaskets ② Valve balls ③ * Springs ④ Valve seats ⑨ Diaphragm * spring-loaded valve only	Material	Double-ball valve	Spring-loaded valve
	PVC / Glass / FPM	28275	27815
	PVC / Glass / CSM	28274	27814
	PP/ Glass / FPM	35567	37496
	PP/ Glass / CSM	35346	37497
	Stainless steel / AF	27808	27820

Complete valves for MEMDOS E/DX 50...76				
Material	⑤ Spring-loaded valve		⑥ Double-ball valve	
	Suction valve	Discharge valve	Suction valve	Discharge valve
PVC / Glass / FPM	25162	27517	18185	18186
PVC / Glass / CSM	25161	27516	18187	18188
PP/ Glass / FPM	35260	35261	35199	35200
PP/ Glass / CSM	34810	34811	34670	34671
Stainless steel / AF	28775	28776	26967	26968

Spare parts sets MEMDOS E/DX 110...156

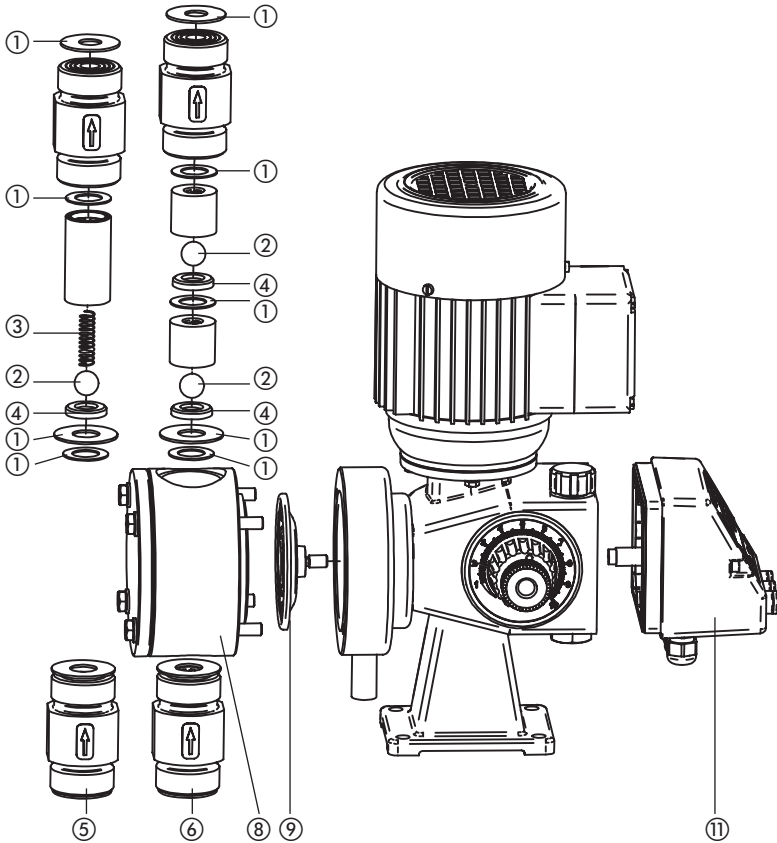

Spare parts sets for valves			
Consisting of:	Material	Double-ball valve	Spring-loaded valve
① Flat gaskets	PP/ Glass / FPM	28301	27817
② Valve balls	PP/ Glass / CSM	28300	28304
③ * Springs	Stainless steel / AF	28302	28306
④ Valve seats			
⑤ Diaphragm			
* spring-loaded valve only			

Complete valves for MEMDOS E/DX 110...156				
Material	⑥ Double-ball valve		⑤ Spring-loaded valve	
	Suction valve	Discharge valve	Suction valve	Discharge valve
PP/ Glass / FPM	26842	27357	25707	27354
PP/ Glass / CSM	26841	27356	26845	27353
Stainless steel / AF	29694	29659	29696	29697

Spare parts sets MEMDOS E/DX 160...260 / E/DX 300...380

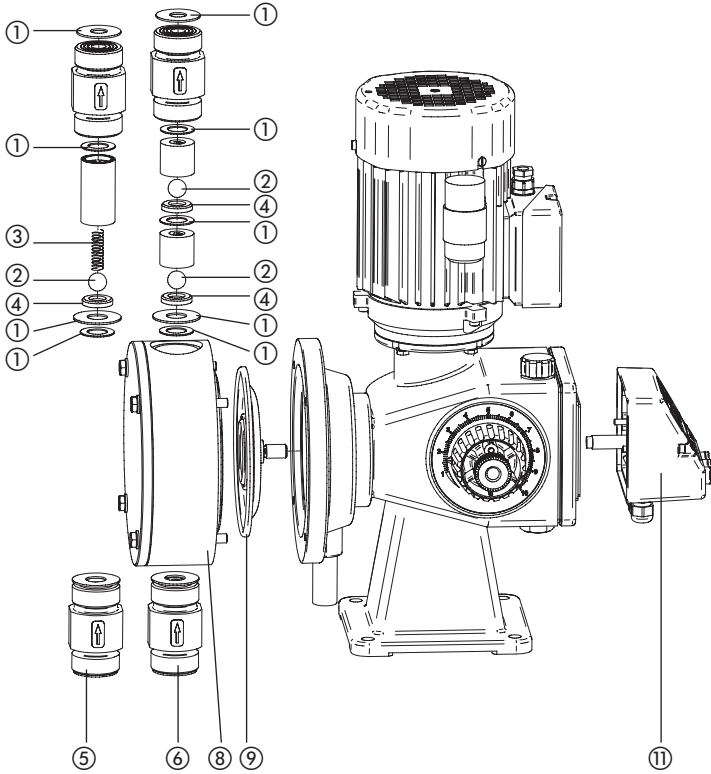

Spare parts sets for valves					
Consisting of: ① Flat gaskets ② Valve balls ③ * Springs ④ Valve seats ⑤ Diaphragm * spring-loaded valve only	Material	Double-ball valve		Spring-loaded valve	
		E/DX 160...260	E/DX 300...380	E/DX 160...260	E/DX 300...380
	PP/ Glass / FPM	28309	28317	28313	28321
PP/ Glass / CSM	28308	28316	28312	28320	
Stainless steel / AF	28310	28318	28314	28322	

Complete valves for MEMDOS E/DX 160...260 / E/DX 300...380				
Material	⑥ Double-ball valve		⑤ Spring-loaded valve	
	Suction valve	Discharge valve	Suction valve	Discharge valve
PP/ Glass / FPM	26842	27357	25707	27354
PP/ Glass / CSM	26841	27356	26845	27353
Stainless steel / AF	29694	29659	29696	29697

15. External vent (optional)

Functional description of vent motors

The fan cowl and fan blade of the drive motor are removed and replaced by the extended fan cowl with integrated fan. The fan has a direct mains connection, and therefore delivers the maximum quantity of cool air to protect the motor against overheating at all speeds. Separate fans can be operated over a wide voltage range, according to the technical data below. They can be connected to three-phase or alternating current power supply, if connected according to the instructions. For single-phase operation, an operating capacitor is included in the terminal box (see electrical wiring diagram). The fan motors work according to the direction of rotation. The air flow must be directed towards the motor.

Special versions available

- Extended fan cowl (for operation with tachogenerator or motor brake)
- Different mounting bracket
- Different fan cowl diameter

Technical Data							
Motor size	63	71	80	90	100	112	
Air flow rate m ³ /h	47	60	88	169	208	295	
Power consumption W	27	30	28,5	86	86	84,5	
Speed at 50 Hz (rpm)	2910	2870	2790	2880	2830	2770	
Sound pressure level dB(A)	47	51	55	58	59	61	
Protection class	IP 66						
Dimensions (mm)	Height	185	190	195	205	210	215
	Diameter	126	143	160	176	196	220
Nominal motor current (A)							
3~, 200...290 V, Delta	0.092	0.095	0.090	0.28	0.27	0.27	
3~, 346...500 V, Y	0.06	0.06	0.05	0.06	0.06	0.06	
1~, 230 V	0.075	0.081	0.090	0.19	0.21	0.23	
Part No.							
Motor supplier ATB	47000200	47000201	47000202	47000203	47000204	47000205	
Motor supplier VEM	-	47000101	47000100	-	-	-	
Motor supplier Siemens	-	-	47000303	-	-	-	

Electrical wiring diagram

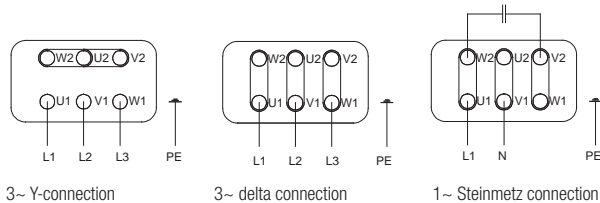

Index

A

Alarm	25
Ambient temperature	11
Analogue control	25
Approximation initiator	30
Area with a potentially explosive atmosphere	17

B

Back-pressure and safety valves	22
Bearings	30

C

Cable assignments	26
Chemical leakage	17
Control unit	12

D

Declaration of no objection	45
Diaphragm replacement	30
Diaphragm wear	31
Dimensional drawings	9
Disposal	29
Dosing head	7
Dosing of chemicals	5

E

Electrical connection	18
Electric motor data	13
Explosion-proof	36
Explosion-proof motors	13

F

Factory setting	26
Fault	37
Function	8

I

Injection nozzle	22
Installation	17
Installation example	23
Installation location	18
Internal error	26

L

Level control	22
Level input	24
Level pre-warning	22
Lubrication	30

M

Maintenance	30
Manual control	25
Media temperature	11

N

Max. number of strokes	26
------------------------------	----

O

Oil inlet	7
Oil outlet	7
Selection of operating mode	24
Operation	24

P

Performance curves	15
Principle of operation	8
Protective clothing	5
Pulse control	25

R

Revision	29
----------------	----

S

Scope of delivery	6
Separate fan	43
Servomotor	14
Shutdown	29
Spare parts	38
Spare parts sets	39
Start-up	28
Stroke frequency	11
Stroke length	11
Stroke length adjustment	24
Stroke volume	11
Structure of the dosing pump	7
Switching on/off	24

T

Technical Data	11
Tightening torque	31
Training	3
Troubleshooting	37

V

Valves	32
--------------	----

W

Warning alarm relay	26
Warranty claim	46
Wiring diagram for electronics	26
Wiring diagram for the drive motor	19

Y

Y-connection	19
--------------------	----

Declaration of no objection

When sending for repair, please copy, fill out and send along with each device.

Declaration of no objection - Form

(please fill out one form for each device and attach it to the outside of the device)

We are returning the following device for repair:

Device and device type:

Part No.:

Order No.:

Date of delivery:

Reason for repair:

Medium conveyed:

Description:

Properties:

Irritant: Yes/No*) Corrosive: Yes/No*)

*) Please delete as appropriate.

We hereby certify that the product has been cleaned thoroughly on the inside and outside before shipment, that it is free from hazardous chemical, biological, or radioactive materials and that the oil has been drained. *)

If the manufacturer finds it necessary to carry out further cleaning work, we will accept the related costs.

We confirm that the above statements are correct and complete and that the device is being shipped according to the legal requirements.

Company:

Address:

.....

.....

Phone:

Fax:

E-mail:

Customer No.:

Contact person:

Date, signature, stamp:

Warranty claim

Please copy and enclose with the unit.

If the equipment fails during the warranty period, please clean it and return, accompanied by the completed warranty claim form.

Sender

Company:..... Phone:..... Date:

Address:.....

Contact person:

Manufacturer order no.:..... Date of delivery:

Device type:..... Serial number:.....

Nominal delivery capacity / nominal pressure:.....

Description of fault:

.....

Type of fault:

1. Mechanical fault

Premature wear

Wear parts

Breakage / other damage

Corrosion

Damage in transit

2. Electrical fault

Connections, connectors or cables loose

Operating controls (e.g. switches / push-buttons)

Electronics

3. Leaks

Connections

Dosing head

4. No or inadequate function

Diaphragm defective

Other

Operating conditions of the equipment

Location / description of installation:

Accessories used if any:

.....

.....

Start-up (date):

Running time (approx. operating hours):

Please indicate the specific features of the installation and enclose a simple sketch showing materials, diameters, lengths and heights.

EU-Konformitätserklärung

Der Unterzeichnete Lutz-Jesco GmbH, Am Bostelberge 19, 30900 Wedemark, bestätigt, dass die nachfolgend bezeichneten Geräte in der von uns in Verkehr gebrachten Ausführung die Anforderungen der harmonisierten EU-Richtlinien, EU-Sicherheitsstandards und produktspezifischen Standards erfüllen. Bei einer nicht mit uns abgestimmten Änderung der Geräte verliert diese Erklärung ihre Gültigkeit.

(EN) EU Certificate of Conformity

The undersigned Lutz-Jesco GmbH, Am Bostelberge 19, 30900 Wedemark, hereby certifies that, when leaving our factory, the units indicated below are in accordance with the harmonised EU guidelines, EU standards of safety and product specific standards. This certificate becomes void if the units are modified without our approval.

(FR) Certificat de conformité aux directives européennes

Le constructeur, soussigné: Lutz-Jesco GmbH, Am Bostelberge 19, 30900 Wedemark, déclare qu'à la sortie de ses usines le matériel neuf désigné ci-dessous était conforme aux prescriptions des directives européennes énoncées ci-après et conforme aux règles de sécurité et autres règles qui lui sont applicables dans le cadre de l'Union européenne. Toute modification portée sur ce produit sans l'accord express de Jesco supprime la validité de ce certificat.

(ES) Declaración de conformidad de la UE

El que suscribe Lutz-Jesco GmbH, Am Bostelberge 19, 30900 Wedemark, declara que la presente mercancía, objeto de la presente declaración, cumple con todas las normas de la UE, en lo que a normas técnicas, de homologación y de seguridad se refiere. En caso de realizar cualquier modificación en la presente mercancía sin nuestra previa autorización, esta declaración pierde su validez.

(NL) EU-overeenstemmingsverklaring

Ondergetekende Lutz-Jesco GmbH, Am Bostelberge 19, 30900 Wedemark, bevestigt, dat het volgende genoemde apparaat in de door ons in de handel gebrachte uitvoering voldoet aan de eis van, en in overeenstemming is met de EU-richtlijnen, de EU-veiligheidsstandaard en de voor het product specifieke standaard. Bij een niet met ons afgestemde verandering aan het apparaat verliest deze verklaring haar geldigheid.

(HU) EG (EK)– Egyezőségi nyilatkozat

A Lutz-Jesco GmbH, Am Bostelberge 19, 30900 Wedemark ezúton kijelenti, hogy a szóban forgó termék annak tervezése és szerkezeti módja, valamint forgalomba hozott kivitele alapján a vonatkozó alapvető biztonságtechnikai és egészségügyi követelményeknek és az alábbi felsorolt EG –irányelveknek minden szempontból megfelel. A terméken engedélyünk nélkül végrehajtott módosítások következtében jelen nyilatkozat érvényét veszíti.

(PT) Certificado de conformidade da UE

Os abaixo mencionados Lutz-Jesco GmbH, Am Bostelberge 19, 30900 Wedemark, por este meio certificam que ao sair da fábrica o aparelho abaixo mencionado está de acordo com as directrizes harmonizadas da UE, padrões de segurança e de produtos específicos. Este certificado ficará nulo se a unidade for modificada sem a nossa aprovação.

Bezeichnung des Gerätes:	Membran-Dosierpumpe
Description of the unit:	Diaphragm Metering Pump
Désignation du matériel:	Pompes doseuses à membrane mécanique
Descripción de la mercancía:	Bombas dosificadoras de membrana
Omschrijving van het apparaat:	Membraandoseerpomp
A termék megnevezése:	Membrán adagolószivattyúk
Designação do aparelho:	

Typ / Type / Tipo / Tipusjelölés:

MINIDOS A

MIDIDOS E

MEMDOS E

MEMDOS M

MEMDOS ML

MEMDOS MR

MEMDOS GMR

MEMDOS TM

EU-Richtlinie / EU directives/
Directives européennes / Normativa UE /
EU-richtlijnen / Vonatkozó EG-irányelvek /
Directrizes da UE

2006/95/EG

2006/42/EG

Harmonisierte Normen / harmonized
standards / Normes harmonisées /
Estándares acordemente / Toegepaste normeringen /
Hatályos normák / Normas harmonizadas

EN ISO 12100-1 : 2003

EN ISO 12100-2 : 2003

EN 809 : 1998

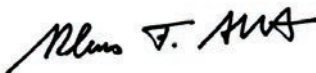

i.V. Dipl. Ing. Klaus Albert
Lutz-Jesco, Wedemark, 21.12.2009

Technische Leitung / Technical Department Manager / Direction technique /
Dirección Técnica / Hoofd technische dienst / Műszaki irodavezető / Director Técnico

EU-Konformitätserklärung

Der Unterzeichnete Lutz-Jesco GmbH, Am Bostelberge 19, 30900 Wedemark, bestätigt, dass die nachfolgend bezeichneten Geräte in der von uns in Verkehr gebrachten Ausführung die Anforderungen der harmonisierten EU-Richtlinien, EU-Sicherheitsstandards und produktspezifischen Standards erfüllen. Bei einer nicht mit uns abgestimmten Änderung der Geräte verliert diese Erklärung ihre Gültigkeit.

(EN) EU Certificate of Conformity

The undersigned Lutz-Jesco GmbH, Am Bostelberge 19, 30900 Wedemark, hereby certifies that, when leaving our factory, the units indicated below are in accordance with the harmonised EU guidelines, EU standards of safety and product specific standards. This certificate becomes void if the units are modified without our approval.

(FR) Certificat de conformité aux directives européennes

Le constructeur, soussigné: Lutz-Jesco GmbH, Am Bostelberge 19, 30900 Wedemark, déclare qu'à la sortie de ses usines le matériel neuf désigné ci-dessous était conforme aux prescriptions des directives européennes énoncées ci-après et conforme aux règles de sécurité et autres règles qui lui sont applicables dans le cadre de l'Union européenne. Toute modification portée sur ce produit sans l'accord express de Jesco supprime la validité de ce certificat.

(ES) Declaración de conformidad de la UE

El que suscribe Lutz-Jesco GmbH, Am Bostelberge 19, 30900 Wedemark, declara que la presente mercancía, objeto de la presente declaración, cumple con todas las normas de la UE, en lo que a normas técnicas, de homologación y de seguridad se refiere, En caso de realizar cualquier modificación en la presente mercancía sin nuestra previa autorización, esta declaración pierde su validez.

(NL) EU-overeenstemmingsverklaring

Ondergetekende Lutz-Jesco GmbH, Am Bostelberge 19, 30900 Wedemark, bevestigt, dat het volgende genoemde apparaat in de door ons in de handel gebrachte uitvoering voldoet aan de eis van, en in overeenstemming is met de EU-richtlijnen, de EU-veiligheidsstandaard en de voor het product specifieke standaard. Bij een niet met ons afgestemde verandering aan het apparaat verliest deze verklaring haar geldigheid.

(HU) EG (EK)– Egyezőségi nyilatkozat

A Lutz-Jesco GmbH, Am Bostelberge 19, 30900 Wedemark ezúton kijelenti, hogy a szóban forgó termék annak tervezése és szerkezeti módja, valamint forgalomba hozott kivitele alapján a vonatkozó alapvető biztonság technikai és egészségügyi követelményeknek és az alábbi felsorolt EG –irányelveknek minden szempontból megfelel. A terméken engedélyünk nélkül végrehajtott módosítások következtében jelen nyilatkozat érvényét veszíti.

(PT) Certificado de conformidade da UE

Os abaixo mencionados Lutz-Jesco GmbH, Am Bostelberge 19, 30900 Wedemark, por este meio certificam que ao sair da fábrica o aparelho abaixo mencionado está de acordo com as directrizes harmonizadas da UE, padrões de segurança e de produtos específicos. Este certificado ficará nulo se a unidade for modificada sem a nossa aprovação.

Bezeichnung des Gerätes:	Membran-Dosierpumpe DX
Description of the unit:	Diaphragm Metering Pump DX
Désignation du matériel:	Pompes doseuses à membrane mécanique DX
Descripción de la mercancía:	Bombas dosificadoras de membrana DX
Omschrijving van het apparaat:	Membraandoseerpomp DX
A termék megnevezése:	Membrán - adagolószivattyú DX
Designação do aparelho:	

Typ / Type / Tipo / Tipusjelölés:

MEMDOS DX

EU-Richtlinie / EU directives/
Directives européennes / Normativa UE /
EU-richtlijnen / Vonatkozó EG-irányelvek /
Diretrizes da UE

2006/95/EG
2006/42/EG
2004/108/EG

Harmonisierte Normen / harmonized
standards / Normes harmonisées /
Estándares acordemente / Toegepaste normeringen /
Hatályos normák / Normas harmonizadas

EN ISO 12100-1 : 2003
EN ISO 12100-2 : 2003
EN 809 : 1998
EN 50081-1 : 01.92
EN 50081-2 : 08.93
EN 50082-1 : 01.92
EN 50082-2 : 03.95

i.V. Dipl. Ing. Klaus Albert
Lutz-Jesco, Wedemark, 21.12.2009

Technische Leitung / Technical Departement Manager / Direction technique /
Dirección Técnica / Hoofd technische dienst / Műszaki irodavezető / Director Técnico

EU-Konformitätserklärung

Der Unterzeichnete Lutz-Jesco GmbH, Am Bostelberge 19, 30900 Wedemark, bestätigt, dass die nachfolgend bezeichneten Geräte in der von uns in Verkehr gebrachten Ausführung die Anforderungen der harmonisierten EU-Richtlinien, EU-Sicherheitsstandards und produktspezifischen Standards erfüllen. Bei einer nicht mit uns abgestimmten Änderung der Geräte verliert diese Erklärung ihre Gültigkeit.

(EN) EU Certificate of Conformity

The undersigned Lutz-Jesco GmbH, Am Bostelberge 19, 30900 Wedemark, hereby certifies that, when leaving our factory, the units indicated below are in accordance with the harmonised EU guidelines, EU standards of safety and product specific standards. This certificate becomes void if the units are modified without our approval.

(FR) Certificat de conformité aux directives européennes

Le constructeur, soussigné: Lutz-Jesco GmbH, Am Bostelberge 19, 30900 Wedemark, déclare qu'à la sortie de ses usines le matériel neuf désigné ci-dessous était conforme aux prescriptions des directives européennes énoncées ci-après et conforme aux règles de sécurité et autres règles qui lui sont applicables dans le cadre de l'Union européenne. Toute modification portée sur ce produit sans l'accord express de Jesco supprime la validité de ce certificat.

(ES) Declaración de conformidad de la UE

El que suscribe Lutz-Jesco GmbH, Am Bostelberge 19, 30900 Wedemark, declara que la presente mercancía, objeto de la presente declaración, cumple con todas las normas de la UE, en lo que a normas técnicas, de homologación y de seguridad se refiere, En caso de realizar cualquier modificación en la presente mercancía sin nuestra previa autorización, esta declaración pierde su validez.

(NL) EU-overeenstemmingsverklaring

Ondergetekende Lutz-Jesco GmbH, Am Bostelberge 19, 30900 Wedemark, bevestigt, dat het volgende genoemde apparaat in de door ons in de handel gebrachte uitvoering voldoet aan de eis van, en in overeenstemming is met de EU-richtlijnen, de EU-veiligheidsstandaard en de voor het product specifieke standaard. Bij een niet met ons afgestemde verandering aan het apparaat verliest deze verklaring haar geldigheid.

(HU) EG (EK)– Egyezőségi nyilatkozat

A Lutz-Jesco GmbH, Am Bostelberge 19, 30900 Wedemark ezúton kijelenti, hogy a szóban forgó termék annak tervezése és szerkezeti módja, valamint forgalomba hozott kivitele alapján a vonatkozó alapvető biztonságtechnikai és egészségügyi követelményeknek és az alábbi felsorolt EG –irányelveknek minden szempontból megfelel. A terméken engedélyünk nélkül végrehajtott módosítások következtében jelen nyilatkozat érvényét veszíti.

(PT) Certificado de conformidade da UE

Os abaixo mencionados Lutz-Jesco GmbH, Am Bostelberge 19, 30900 Wedemark, por este meio certificam que ao sair da fábrica o aparelho abaixo mencionado está de acordo com as directrizes harmonizadas da UE, padrões de segurança e de produtos específicos. Este certificado ficará nulo se a unidade for modificada sem a nossa aprovação.

Bezeichnung des Gerätes:	Explosionssgeschützte Membran-Dosierpumpe
Description of the unit:	Explosion proofed Diaphragm Metering Pump
Désignation du matériel:	Pompes doseuses à membrane mécanique Zone Exx
Descripción de la mercancía:	Bombas dosificadoras de membrana antideflagrante
Omschrijving van het apparaat:	Explosieveilige Membraandoseerpomp EX
A termék megnevezése:	Membrán - adagolószivattyúk robbanásbiztos kivitelben EX
Designação do aparelho:	

Typ / Type / Tipo / Típusjelölés:

MEMDOS MR-Ex
MEMDOS E-Ex

EU-Richtlinie / EU directives/
Directives européennes / Normativa UE /
EU-richtlijnen / Vonatkozó EG-irányelvek /
Directrizes da UE

2006/95/EG
2006/42/EG
94/9/EG

Harmonisierte Normen / harmonized
standards / Normes harmonisées /
Estándares acordemente / Toegepaste normeringen /
Hatályos normák / Normas harmonizadas

EN ISO 12100-1 : 2003
EN ISO 12100-2 : 2003
EN 809 : 1998
EN 13463-1 : 2001

ATEX-Registrier-Nr. : Memdos E: Ex II 2 G c k T4 03 ATEX D085, Memdos MR: Ex II 2 G c k T4 03 ATEX D086

ATEX-Registration No. : Memdos E: Ex II 2 G c k T4 03 ATEX D085, Memdos MR: Ex II 2 G c k T4 03 ATEX D086

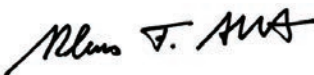

i.V. Dipl. Ing. Klaus Albert
Lutz-Jesco, Wedemark, 21.12.2009

Technische Leitung / Technical Department Manager / Direction technique /
Dirección Técnica / Hoofd technische dienst / Műszaki irodavezető / Director Técnico

Notes

Notes



Lutz-Jesco GmbH

Am Bostelberge 19
30900 Wedemark
Germany

Phone: +49 5130 5802-0
Fax: +49 5130 580268
info@lutz-jesco.com
www.lutz-jesco.com/de

24h-Hotline: +49 5130 580 280

Austria

Lutz-Jesco GmbH

Aredstraße 7/2
2544 Leobersdorf
Austria

Phone: +43 2256 62180
Fax: +43 2256 6218062
info@lutz-jesco.at
www.lutz-jesco.at

Great Britain

Lutz-Jesco (GB) Ltd.

Gateway Estate
West Midlands Freeport
Birmingham B26 3QD
Great Britain

Phone: +44 121 782 2662
Fax: +44 121 782 2680
info@lutz-jesco.com
www.lutz-jesco.com/de

Netherlands

Lutz-Jesco Nederland B.V.

Nijverheidstraat 14 C
2984 AH Ridderkerk
Netherlands

Phone: +31 180 499460
Fax: +31 180 497516
info@lutz-jesco.nl
www.lutz-jesco.nl

Hungary

Lutz-Jesco Üzletág

Vasvári P. u. 9.
9024 Győr
Hungary

Phone: +36 96 523046
Fax: +36 96 523047
info@lutz-jesco.hu
www.lutz-jesco.hu

USA

Lutz-JESCO America Corp.

55 Bermar Park
Rochester, NY 14624
USA

Phone: +1 585 426-0990
Fax: +1 585 426-4025
mail@jescoamerica.com
www.jescoamerica.com

East Asia

Lutz-Jesco
East Asia Sdn Bhd
6 Jalan Saudagar U1/16
Hicom Glenmarie Industrial Park
40150 Shah Alam /Selangor
Malaysia

Phone: +603 5569 2322
Fax: +603 5569 1322
info@lutz-jescoasia.com
www.lutz-jescoasia.com

Middle East

Lutz-Jesco Middle East FZE

P.O. Box 9614
SAIF-Free Zone Center
Sharjah
UAE

Phone: +971 6 5572205
Fax: +971 6 5572230
info@jescome.com
www.jescome.com



BA-10402-02-V04
Subject to technical changes
and inaccuracies
© Lutz-Jesco GmbH 05.2014
Printed in Germany