



BB PEP SERIES

HIGH PRECISION METERING PUMP
ACCELERATED ASSEMBLY, RAPID REBUILD

COLFAX[®]
Fluid Handling

ZENITH[®]

ZENITH PUMPS

A LEGACY OF PRECISION

You demand precision and repeatability from the metering gear pumps you invest in. In 1926, Zenith Pumps established the standard for gear pumps for the extrusion of Rayon. This revolutionary design became the foundation for development of the synthetic fiber industry. During the next 55 years, innovations from Zenith Pumps contributed to major improvements in the polymer industry. In the early 1980's, Zenith again established itself as a leader with the original PEP (Polymer Extrusion Pump) design for the extrusion of film, sheet and profile. In 1990, the Zenith PEP-II Extrusion Pump line was introduced, creating new standards for pulse isolation and reduced temperature rise, improving product consistency and control.

SIMPLY BETTER

The new BB PEP incorporates a design that meets or exceeds industry requirements for precise, accurate performance, while significantly reducing the time and cost of maintenance. Enhancements include:

- Long life and robust construction with hardened tool steel.
- Assembly time reduced by nearly 90 percent, with 50 percent fewer parts.
- No small parts or special tools required.
- Reduced part damage, simpler assembly, and less leakage with revolutionary B-Bearing design.
- Interchangeable with existing designs for easy upgrades.

SPECIFICATIONS

Flow Rates	.2 to 25 lbs/hr (4cc/min to 600 cc/min)
Pump Speed	25-220 RPM, depending on process parameters
Pressures	Body Pressure up to 10,000 psi. Differential Pressure up to 4,000 psi.
Temperature	600°F is the standard max temperature (950°F with special fasteners and seals)

PUMP CAPACITY

Capacity CC/REV	Flow rate LBS/HR	Extruder Size, IN	Typical drive HP
0.16	0.2 - 1.25	.25	0.5
0.3	.04-2.5	.25, .5	0.5
0.6	.8 - 5	.5	0.5
1.2	1.5 - 9.0	.5	0.5
1.8	2.4 - 14	.5	0.5
3	4 - 24	.75, 1.0	0.5

NOTE: These are typical sizes only; others are available. Actual pump and drive size will vary with viscosity, pressure and other factors. Contact Zenith for further assistance.

REQUIRED PUMP TORQUE CALCULATION

$$\text{TORQUE (lb-in)} = K_1 * \Delta P + (K_2 * N * \mu)$$

$K_1 =$	Constant from chart
$N =$	Rev. per minute
ΔP	Differential pressure in psi
$K_2 =$	Constant from chart
$\mu =$	Maximum fluid viscosity in poise

CC/REV (IN-LB)	K_1	K_2	Max Torque
0.16	.0016	.0011	45
0.3	.0029	.0011	80
0.6	.0058	.0011	195
1.2	.0113	.00469	300
1.8	.0175	.0014	410
3.0	.0291	.0014	600

BB PEP SERIES (0.16 - 3 CC/REV)

DIMENSIONAL DIAGRAM

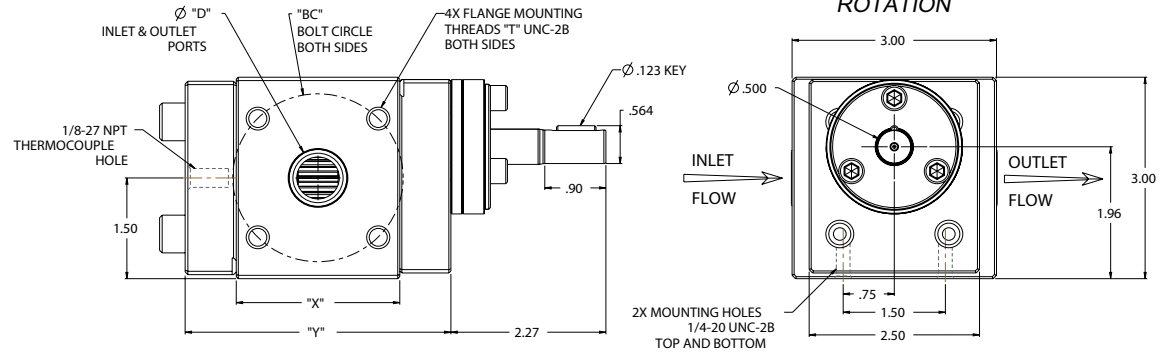

DIMENSIONAL DATA CHART

PUMP CAPACITY	D	BC	T	X	Y	MAX TORQUE	APPROX WEIGHT
0.16	.125					45	
0.3	.25	1.50	1/4" - 20	1.61	3.11	80	7.5
0.6	.375					195	
1.2	.75					300	
1.8	.75	2.50	5/16" - 18	2.40	3.90	410	9.0
3.0	1.00					600	
CC/REV	PUMP DIMENSIONS ARE IN INCHES					IN-LBS	LBS

MATERIALS OF CONSTRUCTION DIAGRAM AND CHART

ITEM	QTY	DESCRIPTION	MATERIAL
1	1	Driving gear/shaft	Tool steel
2	1	Center plate	Tool steel
3	1	Front plate	Tool steel
4	1	Rheoseal	Tool steel
5	1	Rear plate	Tool steel
6	2	Bearing	Tool steel
7	1	Driven gear/shaft	Tool steel
8	4	Socket head screw	Alloy steel
9	2	Metal C-ring	
10	1	Key, external	Steel
11	1	Seal housing	Tool steel
12	1	Lip seal	UHMWPE
13	3	Socket head screw	Alloy steel

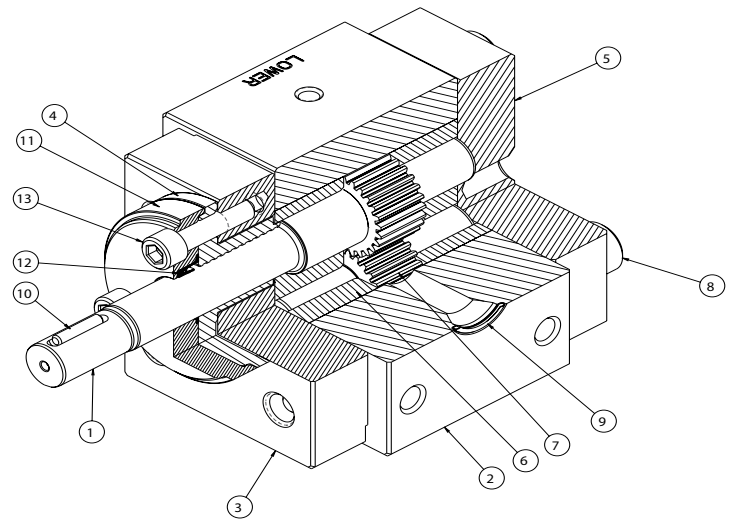

EXPLODED VIEW OF BB PEP GEAR PUMP

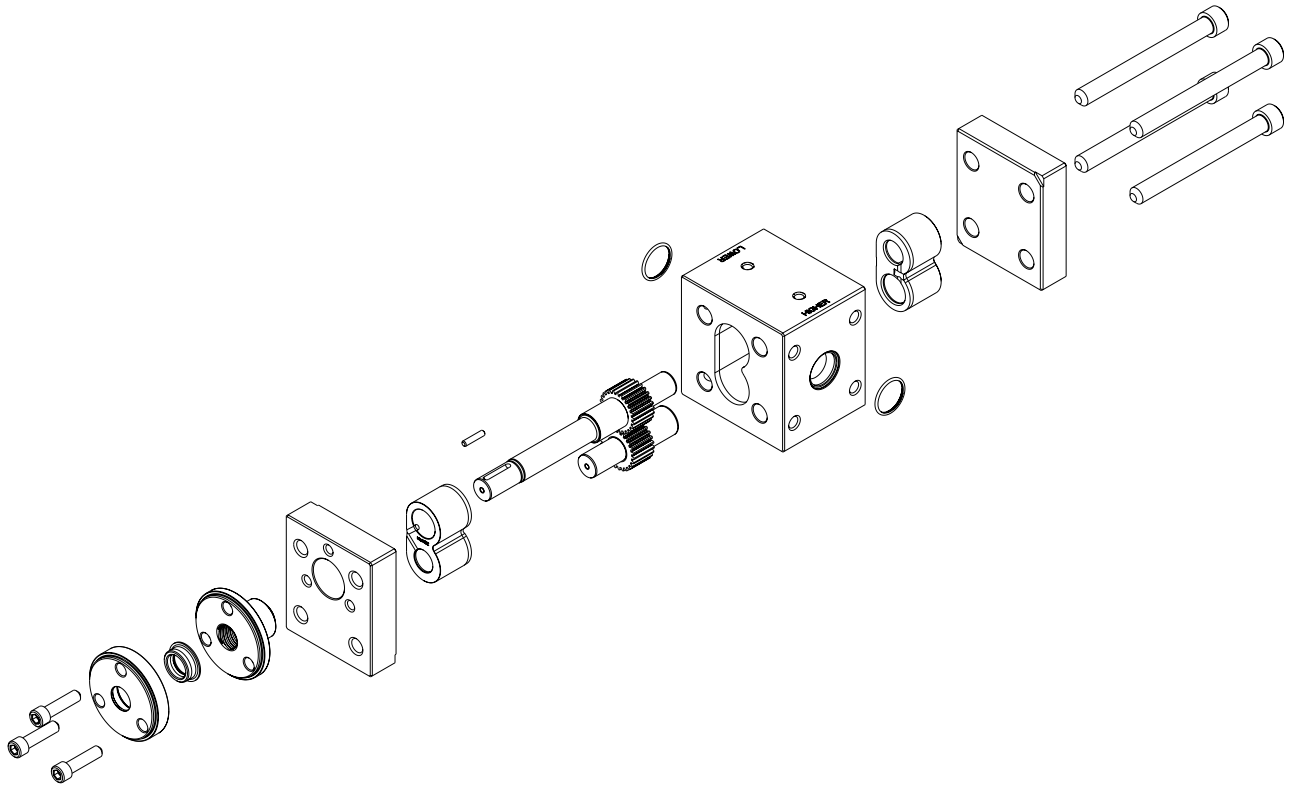

Zenith Pumps

1710 Airport Road
P.O. Box 5020
Monroe, NC 28110
USA

Tel: +1.704.289.6511
Tol: +1.877.853.7867
www.zenithpumps.com

ISO 9001:2008 Certified



Certifications available.

COLFAX[®]
Fluid Handling

ZENITH[®]